

RAPORTTEJA  
RAPPORTER  
REPORTS

No. 2004: 7

551.510.4  
551.506  
543.544  
543.7

**THE FIRST NY-ÅLESUND – PALLAS-SODANKYLÄ  
ATMOSPHERIC RESEARCH WORKSHOP, PALLAS,  
FINLAND 1-3 MARCH 2004 – EXTENDED ABSTRACTS**

Jussi Paatero and Kim Holmén (Eds.)

Ilmatieteen laitos  
Meteorologiska institutet  
Finnish Meteorological Institute

Helsinki 2004

ISBN 951-697-605-0  
ISSN 0782-6079

Oy Edita Ab  
Helsinki 2004

Published by



Finnish Meteorological Institute  
P.O. Box 503  
FIN-00101 HELSINKI  
Finland

Series title, number and report code of publication

Reports No. 2004:7

Date

2004

Name of project

Commissioned by

Authors

Jussi Paatero and Kim Holmén (Eds.)

Title

THE FIRST NY-ÅLESUND – PALLAS-SODANKYLÄ ATMOSPHERIC RESEARCH  
WORKSHOP, PALLAS, FINLAND 1-3 MARCH 2004 – EXTENDED ABSTRACTS

Abstract

The Finnish Meteorological Institute (FMI) and the Norwegian Institute for Air Research (NILU), together with the Stockholm University, Department of Meteorology (MISU), are both operating a global background station of the Global Atmosphere Watch (GAW) programme conducted by the World Meteorological Organization (WMO). The Norwegian station is at Mt. Zeppelin, Ny-Ålesund, Svalbard, and the Finnish one at Pallas and Sodankylä in northern Finland.

The Finnish Meteorological Institute (FMI) and the Norwegian Institute for Air Research arranged The First Ny-Ålesund – Pallas-Sodankylä Atmospheric Research Workshop at Pallas, Finland 1-3 March 2004. The purpose of the workshop was to change ideas and data and to seek new opportunities for cooperation between Norwegian, Swedish and Finnish working in the field of atmospheric sciences. This report contains the extended abstracts of the workshop.

Publishing unit

**Air Quality Research**

Classification (UDC)

551.510.4; 551.506;  
543.544; 543.7

Key words

Atmospheric research, workshop extended  
abstracts, Pallas GAW station

ISSN and series title

0782-6079 Reports

Language

English

ISBN

951-697-605-0

Sold by

Finnish Meteorological Institute, Library,  
P.O.Box 503, FIN-00101 Helsinki, Finland

Pages

61

Price

Note

## TABLE OF CONTENTS

PREFACE .....	5
WORKSHOP PROGRAMME.....	7
LIST OF PARTICIPANTS .....	10
EXTENDED ABSTRACTS.....	11
C. Lunder et al. ....	12
J. Hatakka .....	16
J. Paatero et al. ....	19
T. Aalto et al. ....	23
H. Hakola and H. Hellén .....	26
H. Lihavainen et al. ....	30
K. Teinilä et al. ....	34
K. Tørseth .....	36
A. Virkkula et al. ....	37
U. Raffalski and S. Kirkwood.....	41
T. Ruuskanen et al. ....	47
V.-M. Kerminen and H. Korhonen.....	50
C. Eneroth and K. Holmén .....	55
U. Makkonen .....	59

**THE FIRST NY-ÅLESUND – PALLAS-SODANKYLÄ  
ATMOSPHERIC RESEARCH WORKSHOP, PALLAS, FINLAND  
1-3 MARCH 2004**

**PREFACE**

The Zeppelin station in Ny-Ålesund on Svalbard (maintained by the Norwegian Institute of Air Research (NILU) together with Stockholm University (SU) and the Norwegian Polar Institute) and the Pallas-Sodankylä observation sites (maintained by the Finnish Meteorological Institute (FMI)) in Northern Finland have been operational atmospheric monitoring stations for a number of years. Both are contributors to many international programs including Global Atmospheric Watch, Arctic Monitoring and Assessment Program and EMEP (Co-operative Programme for Monitoring and Evaluation of the Long-Range Transmission of Air pollutants in Europe) to mention some important networks.

There has been a fair amount of exchange over the years between the individual scientists involved with various measurements but there is a general feeling that we could achieve even more and utilize the data more efficiently by deepening our contacts. Such thinking led to suggesting joint workshops in order to promote scientific exchange with the intention to create new opportunities for usage of the accrued data. FMI very kindly offered to host the first workshop in this series. The meeting was held in Pallas in early March 2004. The marvelous Pallas hotel venue also allowed a field trip to the Pallas research station.

The attendance at this first workshop was broadened beyond the station scientists to include a number of others active in the atmospheric sciences in Norway, Sweden and Finland for several reasons. A primary reason was that the stimulus provided by viewpoints from other scientists ensured a high level of scientific debate through the days of the workshop. Scientifically it was also timely to discuss possible joint Nordic initiatives within the upcoming International Polar Year (IPY 2007/2008) with other groups. The three nations are furthermore presently involved in upgrading their Antarctic activities in Queen Maud Land (QML). The groups invited to the workshop are largely the same groups that are (or will be) contributing to the atmospheric programs within the respective national efforts on Antarctica. We as scientists felt it to be appropriate to seek cooperation in order to conceive a scientifically forceful and cost efficient concerted atmospheric program for the QML stations.

The workshop attracted almost 30 scientists from NILU, SU, FMI and The Swedish Institute of Space Physics. This volume contains some of the work presented during the meeting. The discussions were rewarding for all of us attending and are already leading to some new joint publications and concrete plans for cooperation in QML as well as within the IPY framework. To all of us this was a stimulating meeting and we foresee making this a regular event where the two stations meet with some invited guests to discuss scientific issues of relevance. The very pleasant and successful arrangements provided by FMI at this first workshop will be a tough challenge for NILU to meet when hosting the next meeting that is planned to occur in Ny-Ålesund.

We that were guests thank FMI for the generous hospitality and this very successful start of a forthcoming tradition.

Kim Holmén

NILU

On behalf of the FMI I would like to take the opportunity to thank all the participants for the scientifically productive days at Pallas, the staff of the hotel Pallas for the pleasant stay, Dr. Yrjö Norokorpi, Mr. Tapani Rauhala and the team of snowmobile drivers, Pallas-Ounastunturi National Park, for their logistical support, and Mr. Ahti Ovaskainen, Finnish Forest Research Institute, for arranging the field lunch at the Matolampi cabin. The workshop was sponsored by Nordic Center of Excellence, Research Unit on Biosphere - Aerosol - Cloud - Climate Interactions (BACCI).

Jussi Paatero

FMI

## WORKSHOP PROGRAMME

Hotel Pallas, conference room

### Monday 1 March

11:30-13:00 Flight Helsinki-Kittilä

13:30-14:30 Bus from Kittilä airport to hotel Pallas

15:00 Coffee

Session 1 – Chairpersons Kim Holmén and Yrjö Viisanen

15:10-15:15 Kim Holmén and Yrjö Viisanen: Opening remarks

15:15-15:30 Yrjö Viisanen: "Overview of scientific activities at Pallas-Sodankylä GAW station"

15:30-15:45 Chris Lunder: "Monitoring of Climate Gases at Zeppelin - some results"

15:45-16:00 Juha Hatakka and Jussi Paatero: "Greenhouse gas measurements at Pallas and radionuclide measurements at Pallas-Sodankylä and Mt. Zeppelin GAW stations"

16:00-16:15 Kim Holmén: "Modeling of Greenhouse gases at Mt. Zeppelin"

16:15-16:30 Tuula Aalto: "Carbon dioxide observations at Pallas"

16:30-16:45 Hannele Hakola: "Measurements of organic compounds at Pallas"

16:45-17:00 Tuomas Laurila: "Ozone and micrometeorological studies at Pallas-Sodankylä GAW station"

17:00-17:15 break

17:15-17:30 Esko Kyrö: "Upper air GAW observations at Sodankylä, Finland"

17:30-17:45 Johan Ström: "Aerosol measurements by Stockholm University at the Zeppelin station"

17:45-18:00 Heikki Lihavainen: "Aerosol measurements at Pallas"

18:00-18:15 Kimmo Teinilä: "NICE campaign measurements at Ny-Ålesund, Svalbard"

18:15-18:30 Kjetil Tørseth: "Multi-purpose monitoring in Europe, the monitoring strategy of EMEP in relation to other initiatives and with a particular focus on the collaboration with WMO-GAW on joint supersites"

18:30-18:45 Georg Hansen: "A possible new initiative of an EU atmospheric infrastructure network focusing on climate gasses and aerosols"

19:30 dinner

## **Tuesday 2 March**

*Session 2 – Chairpersons Sheila Kirkwood and Tuomas Laurila*

9:00-9:15 Ismo Koponen: "Aerosol physics studies at Aboa, Antarctica"

9:15-9:30 Aki Virkkula "FMI's aerosol research at Aboa, Antarctica"

9:30-9:45 Radovan Krejci: "In situ Arctic and Antarctic airborne aerosol observations: Objectives and links to ground based measurements"

09:45-10:00 Sheila Kirkwood: "Atmospheric Measurements in Kiruna and Wasa Antarctica - present status and ideas for the future"

10:00-10:15 Kim Holmén: "Status of Norwegian air-monitoring plans on Antarctica"

10:15-16:00 Visit to Sammaltunturi monitoring station, field lunch, visit to Matorova and Kenttäröva monitoring stations, visit to Pallas-Ounastunturi national park visitors' centre

16:00 Coffee

*Session 3 – Chairpersons Kjetil Tørseth and Aki Virkkula*

16:15-16:30 Taina Ruuskanen: "Atmospheric research at SMEAR I station, Värriö, eastern Lapland"

16:30-16:45 Veli-Matti Kerminen: "Aerosols in large-scale atmospheric models: future direction and needs"

16:45-17:00 Kristina Eneroth: "Multi-species interpretation at Mt. Zeppelin – using a trajectory climatology"

17:00-17:15 Kim Holmen: "IPY background and status of Norwegian planning"

18:00 Sauna

20:00 Workshop dinner

## **Wednesday 3 March**

*Session 4 – Chairpersons Johan Ström and Heikki Lihavainen*

9:00 – 10:30 General discussions



- i) New Pallas – Zeppelin projects
  - a. Measurements
  - b. Modeling
  - c. Comparisons
- ii) New EC or other proposals?
- iii) Antarctic cooperation and strategies?
- iv) A joint IPY initiative?

10:30 coffee

11:30 Bus to Kittilä airport

13:35 Flight to Helsinki

**LIST OF PARTICIPANTS**

1. Aki Virkkula, FMI/Air Quality Research, Finland
2. Kimmo Teinilä, FMI/Air Quality Research, Finland
3. Juha Hatakka, FMI/Air Quality Research, Finland
4. Heikki Lihavainen, FMI/Air Quality Research, Finland
5. Yrjö Viisanen, FMI/Air Quality Research, Finland
6. Veli-Matti Kerminen, FMI/Air Quality Research, Finland
7. Ismo Koponen, University of Helsinki, Department of physical sciences, Finland
8. Taina Ruuskanen, University of Helsinki, Department of physical sciences, Finland
9. Kim Holmén, NILU, Norway
10. Kjetil Tørseth, NILU, Norway
11. Tuula Aalto, FMI/Air Quality Research, Finland
12. Hannele Hakola, FMI/Air Quality Research, Finland
13. Juha-Pekka Tuovinen, FMI/Air Quality Research, Finland
14. Tuomas Laurila, FMI/Air Quality Research, Finland
15. Ulla Makkonen, FMI/Air Quality Research, Finland
16. Esko Kyrö, FMI/Arctic Research Centre, Finland
17. Rigel Kivi, FMI/Arctic Research Centre, Finland
18. Kristina Eneroth, MISU, Sweden
19. Radovan Krejci, ITM, Sweden
20. Uwe Raffalski, Swedish Institute of Space Physics, Sweden
21. Sheila Kirkwood, Swedish Institute of Space Physics, Sweden
22. Georg Hansen, NILU, Norway
23. Ine-Therese Pedersen, NILU, Norway
24. Chris Lunder, NILU, Norway
25. Johan Ström, ITM, Sweden
26. Kevin Noone, MISU, Sweden
27. Andreas Dörnbach, DLR, Germany
28. Jussi Paatero, FMI/Air Quality Research, Finland

**EXTENDED ABSTRACTS**

## MONITORING OF CLIMATE GASES AT ZEPPELIN – SOME RESULTS

Chris Lunder, Ove Hermansen, Norbert Schmidbauer, Jan Schau  
Norwegian Institute for Air Research (NILU), Instituttveien 18, 2027 Kjeller, Norway  
(email: Chris.Lunder@nilu.no)

### INTRODUCTION

NILU is responsible for the scientific programmes at the Zeppelin Station and coordinating the scientific activities undertaken by NILU and other institutions, as well as a number of international research groups' campaigns. Stockholm University (SU) cooperates closely with NILU in developing the scientific activities and programmes at the station. The Zeppelin Station is owned and operated by Norwegian Polar Institute. The monitoring and research programmes address several issues, such as: climate change, arctic stratospheric ozone layer depletion, global distribution of toxic pollutants, distribution of radioactive contaminants.



**Figure 1.** The Zeppelin Station

The Zeppelin activities contribute to regional, national and global monitoring networks such as European Monitoring and Evaluation Programme (EMEP), Network for detection of Stratospheric Change (NDSC), Global Atmospheric Watch (GAW), Arctic Monitoring and Assessment Programme (AMAP), National Oceanic and Atmospheric Administration – Climate Monitoring and Diagnostics Laboratory (NOAA-CMDL) and System for Observation of halogenated Greenhouse gases in Europe (SOGE).

### MATERIALS AND METHODS

#### *Greenhouse gases*

NILU has for several years measured greenhouse gases at Zeppelin Station. Instruments as Gas Chromatograph (GC) and GC coupled with a mass spectre detector (GC-MS) monitor the most important greenhouse gases from hour to hour. These instruments measure methane, carbon mono oxide, ozone and industry related greenhouse gases containing fluorine, chlorine and bromine (CFC, HCFC, HFC). Hydrocarbons and aldehydes has been sampled earlier but are not sampled at the moment due to lack of funding. SU maintains a continuous infrared CO<sub>2</sub> instrument on Zeppelin Mountain.

The continuous data are enhanced by weekly flask sampling programme in co-operation with the CMDL network. The flask data give CO<sub>2</sub>, H<sub>2</sub>, N<sub>2</sub>O, SF<sub>6</sub>, CH<sub>4</sub> and CO data.

#### *Particles and aerosols*

NILU has for several years measured black carbon with an Aethalometer AE-10 and for the last 3 years run the AE-10 in parallel with an Aethalometer AE-31 operated by Kostas Eleftheriadis at Inst. for Nuclear Technology - Radiation Protection, Greece. NILU also operates a Sun Photometer. This is located in Ny-Ålesund and not at Mt. Zeppelin and was installed in spring 2002.

SU has several instruments at Zeppelin Station that measure particles in the atmosphere. The optical particle counter (OPC) gives the concentration of aerosol particles and, combined with data from the nephelometer, clues to the particles' age and origin. Size distribution is acquired from a differential mobility analyser (DMA). SU also measure black carbon.

#### *POP's*

For the last 20 years NILU has carried out research on persistent organic pollutants (POPs) and heavy metals in the Arctic; since 1993 this has been done on routine basis at Zeppelin Station. The results are reported to AMAP.

#### *Inorganic components in air and precipitation*

Since 1974 NILU has measured concentrations of sulphur components in the air in Ny-Ålesund. Measurements of inorganic components in precipitations started in 1981. Today the measurements are included in the EMEP programme. SO<sub>2</sub>, SO<sub>4</sub><sup>2-</sup>, (NO<sub>3</sub><sup>-</sup> + HNO<sub>3</sub>) and (NH<sub>4</sub><sup>+</sup> + NH<sub>3</sub>) are measured in air and 10 parameters in precipitations.

#### *Stratospheric ozone*

NILU has instruments that measure ozone thickness and some of the chemical compounds destroying ozone. The instrument use optical methods to discern the attenuation of solar radiation through the atmosphere. The reduction of the ozone layer is a concern mainly because ozone shelters the Earth's surface from harmful ultraviolet (UV) radiation, which is also measured at ground level.

#### *Heavy metals*

With a mercury monitor gas phase mercury is observed during the year and results are reported to AMAP. Other heavy metals as As, Cd, Co, Cr, Cu, Pb, Mn, Ni, V, Z are trapped on filters.

#### *Radon-isotope*

University of Heidelberg measure the radon<sup>222</sup> isotope using a monitor.

#### *Lead isotope*

Finnish Meteorological Institute (FMI) has since early 2001 sampled Pb<sup>210</sup>-isotope on filters.

## RESULTS AND DISCUSSION

*CFC, HCFC, HFC - SOGE*

SOGE is an integrated system for observation of halogenated greenhouse gases in Europe. SOGE builds on a combination of observations and modelling. High resolution in situ observation at four background stations forms the backbone of SOGE. A network is being developed between the four stations (Zeppelin, Mace Head, Jungfraujoch, Mt Cimone). This includes full inter-calibration and common quality control that is adopted from the global monitoring network of Advanced Global Atmospheric Gases Experiment (AGAGE).

Results from the four SOGE stations of the replacement gas HFC-134a showing a yearly increase of 20% the last two years and also showing that Zeppelin is a baseline station compared to the other stations (figure 2).

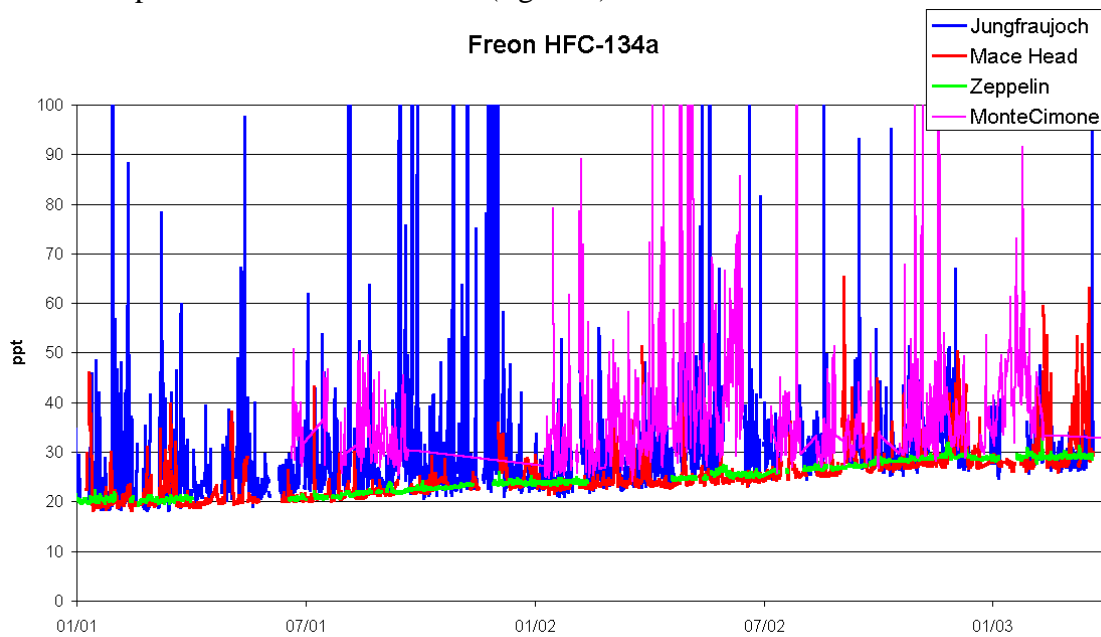

**Figure 2.** HFC-134a results at the four SOGE stations.

*Methane and CO*

Figure 3 shows results of measurements of methane and carbon monoxide in the years 2001 to 2002 at Mt Zeppelin.

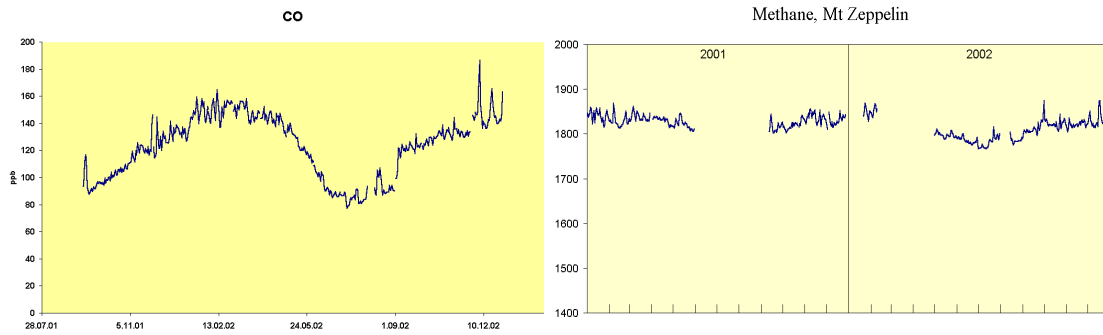
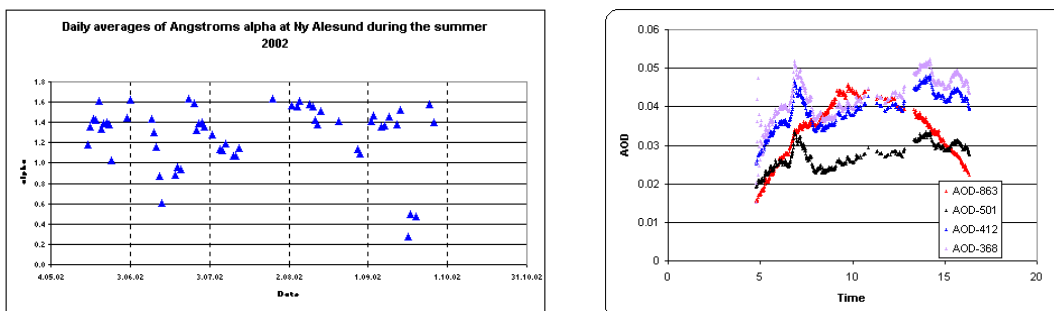

**Figure 3.** Results from year 2001 – 2002 of carbon monoxide (left) and methane (right) measurements at Mt. Zeppelin. (Methane scale in ppb.)

### *Aerosols, Sun Photometer*

A sun photometer needs a clear sky towards the sun in order to give useful data, and this limits the data capture at Ny Ålesund. The photometer measurements were started 1<sup>st</sup> May 2002 and the photometer was operated until 15<sup>th</sup> October, and giving useful data from 66 days only. On clear days during the Arctic summer the photometer on the other hand, in principle, could measure both day and night due to the midnight sun.

The Ångström exponent,  $\alpha$ , that can be calculated from the AOD, is sensitive to the aerosol size distribution. A small  $\alpha$  indicates a high number of the larger particles; normally this exponent will vary between 2.0 and 0.5. A time series of  $\alpha$  will therefore give information on the variation in the particle size distribution during the measurement period. AOD is the scattering due to airborne particles and depends on the particle amount in a column from the instrument ( $\sim$  sea level) to the top of the atmosphere directed towards the sun. The AOD that can be determined from the sun photometer measurements will obtain different values at different light wavelengths due to the scattering's dependence on the particles size.



**Figure 4.** Daily average of Ångström's  $\alpha$  at Ny-Ålesund during the summer 2002 (left) and the AOD-values 16. September 2002.

Figure 4 (left) presents the daily averages of Ångström's  $\alpha$ , which in general are higher than 0.5 except for 16th September. The corresponding AOD in Figure 4 (right) show an increase in the AOD at 863 nm on that day, indicating a shift in the particle size distribution with larger particles passing the column from the morning culminating at 10 GMT.

## GREENHOUSE GAS MEASUREMENTS AT PALLAS

Juha Hatakka

Finnish Meteorological Institute, P.O.Box 503, FI-00101 Helsinki, Finland  
(email: juha.hatakka@fmi.fi)

### INTRODUCTION

Finnish Meteorological Institute's (FMI) measuring stations at Pallas and Sodankylä in northern Finland form together WMO's Global Atmosphere Watch (GAW) station. Pallas-Sodankylä was incorporated into the GAW programme in 1994.

Pallas lies at the northernmost limit of the northern boreal forest zone. There are four stations within 12 km of each other, each with different measurement programs (see Fig. 1). The area has no significant local or regional pollution sources.

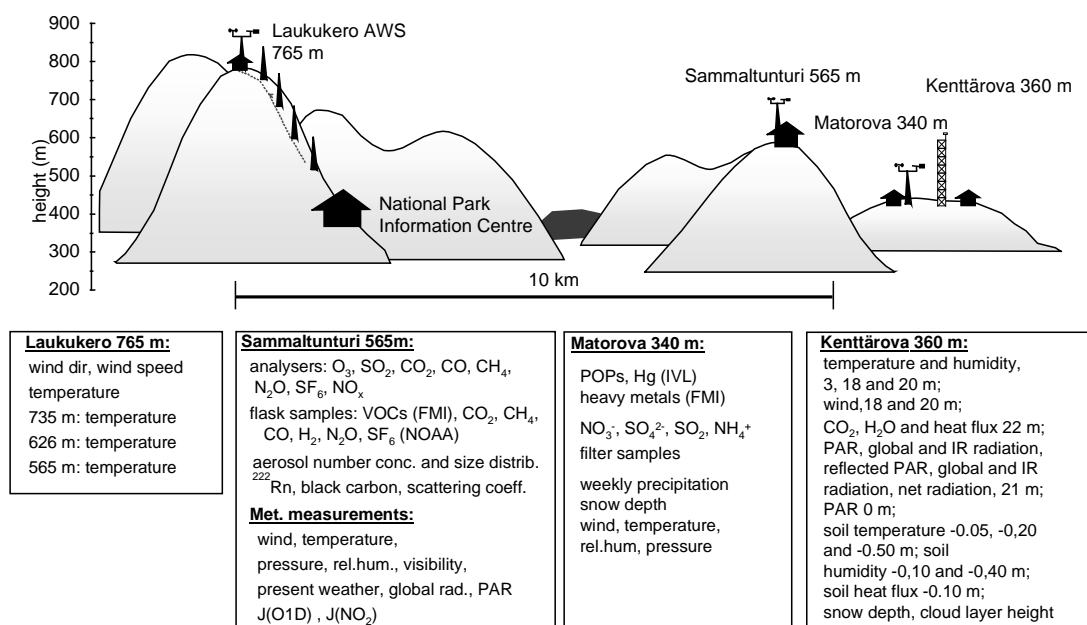

**Figure 1.** FMI's stations and measurement programs at Pallas.

Continuous CO<sub>2</sub> measurements at Pallas GAW station Sammaltunturi were started in autumn 1996 (Hatakka et al., 2003a). A GC-system for measuring methane (CH<sub>4</sub>), carbon monoxide (CO), nitrous oxide (N<sub>2</sub>O) and sulphur hexafluoride (SF<sub>6</sub>) was installed at Sammaltunturi station in February 2004.

### CARBON DIOXIDE MEASURING SYSTEM

Original CO<sub>2</sub> measuring system, running from autumn 1996 to spring 1998, was built and installed by Meteorological Service, Canada. FMI installed its own system in summer 1998. The system (Fig. 2) is based on NDIR analyser from Li-Cor. CO<sub>2</sub>



concentration is measured continuously as 1-minute means. One reference (R) and three station standards (H, M, L) are in use. Reference gas flow rate is 10 ml/min, and sample gas flow rate is 100 ml/min. Station standards are measured every 2.5 hours for five minutes each, in addition the reference gas is measured every 7.5 h. Reference and station standard gases are calibrated against a set of seven WMO/CCL (NOAA/CMDL) calibration gases every 2-3 months using the same system (Hatakka et al., 2003b).

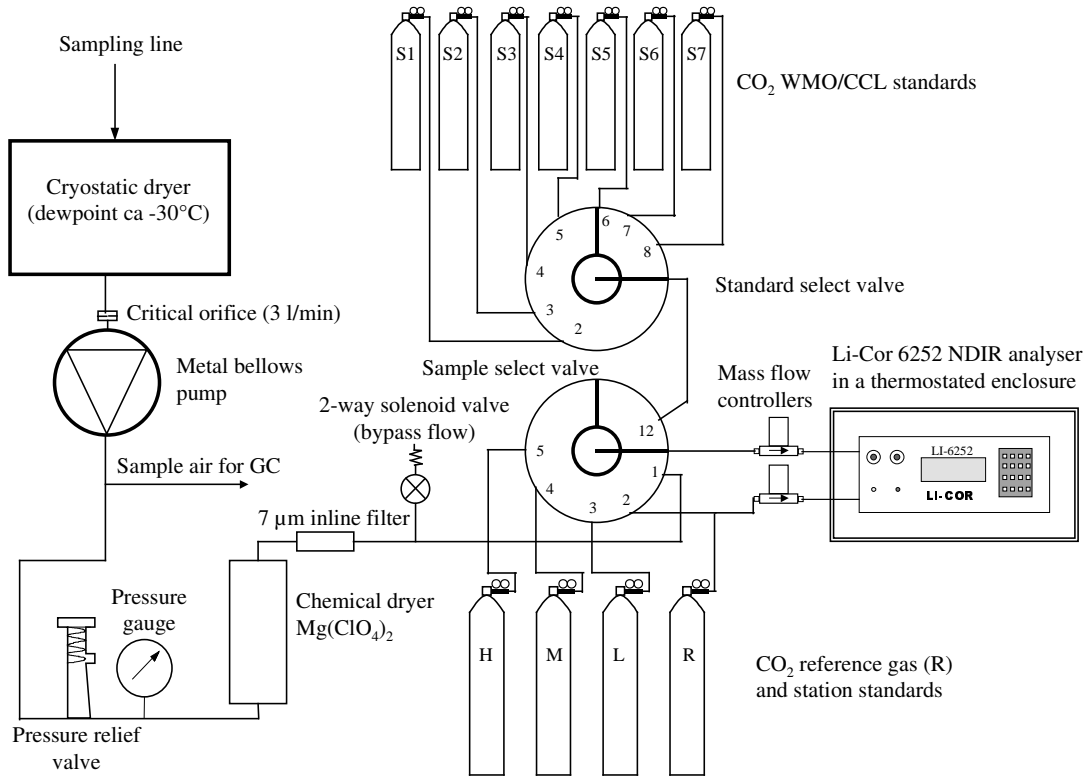

**Figure 2.** Schematic diagram of the CO<sub>2</sub> measurement system.

Carbon dioxide and other greenhouse gases are also measured by NOAA from flask samples collected once a week at Sammaltunturi station (NOAA cooperative sampling network) since January 2002. Station is also participating in international “round robin” intercomparisons arranged by NOAA, and in EU-project TACOS CO<sub>2</sub> “Melon” intercomparison.

#### GC SYSTEM FOR MEASURING CH<sub>4</sub>/CO/N<sub>2</sub>O/SF<sub>6</sub>

A gas chromatograph (GC) system for CH<sub>4</sub>/CO/N<sub>2</sub>O/SF<sub>6</sub> was built and taken into use at Sammaltunturi station in February 2004. Instrument is based on a Agilent GC with FID and ECD detectors. GC's running parameters are presented in Table 1.

Carbon monoxide is measured with FID after converting it to methane with a Nickel catalyst. Sample and working standard are measured alternately. One measurement takes 7.5 minutes, i.e. 4 air and working standard samples are measured in an hour. Working standards are calibrated against 3 CH<sub>4</sub>, 3 CO, and 5 N<sub>2</sub>O/SF<sub>6</sub> calibration

standards from NOAA. System participates in EU-project Meth-MonitEUR CH<sub>4</sub> intercomparisons.

**Table 1.** Running parameters of the Sammaltunturi GC system

Specifics	CH <sub>4</sub> and CO	N <sub>2</sub> O and SF <sub>6</sub>
Detectors, support gas flow rates and temperatures	FID 170°C H <sub>2</sub> flow 63 ml/min Air flow 240 ml/min Ni-catalyst 375 °C	ECD 385 °C
Oven temperature	90 °C	90 °C (same oven)
Sample loop size	10 ml	10 ml
Columns and flow rates	Pre-column: 1.1 m 3/16” SS packed Molecular Sieve 5A mesh 80-100  Analytical column: 1.2 m 1/8” SS packed Unibeads 1S mesh 60-80 Carrier: 42 ml/min N <sub>2</sub>	Pre-column: 2 m 3/16” SS packed HayeSep Q mesh 100-120  Analytical column: 3 m 3/8” SS HayeSep Q mesh 100-120 Carrier: 43 ml/min P-5 (95% Ar / 5% Me)
Repeatability (estimate)	CH <sub>4</sub> : 2 ppb CO: 2 ppb	N <sub>2</sub> O: 0.4 ppb SF <sub>6</sub> : 0.06 ppt
Run time	7.5 minutes (8 samples/hour)	7.5 minutes (8 samples/hour)

## REFERENCES

Hatakka, J., Aalto, T., Aaltonen, V., Aurela, M., Hakola, H., Komppula, M., Laurila, T., Lihavainen, H., Paatero, J., Salminen, K. and Viisanen, Y., 2003a. Overview of the atmospheric research activities and results at Pallas GAW station. *Boreal Environment Research* 8: p. 365-383. Available from <http://www.borenv.net>.

Hatakka, J., Aalto, T. and Viisanen, Y., 2003b. Carbon dioxide measurements at the Pallas GAW station, Finland. In: Report of the eleventh WMO/IAEA meeting of experts on carbon dioxide concentration and related tracer measurements techniques, Tokyo, Japan, 25-28 September 2001. *WMO/GAW report no. 148*, March 2003, p 132-135. Available as <http://www.wmo.int/web/arep/reports/gaw148.pdf>.

## MONITORING OF AIRBORNE NATURAL RADIONUCLIDES AT PALLAS-SODANKYLÄ AND MT. ZEPPELIN GAW STATIONS

Jussi Paatero<sup>1</sup>, Juha Hatakka<sup>1</sup>, Veijo Aaltonen<sup>1</sup>, Kim Holmén<sup>2</sup>, Esko Kyrö<sup>1</sup> and Yrjö Viisanen<sup>1</sup>

<sup>1</sup>Finnish Meteorological Institute, Sahaajankatu 20E, FI-00880 Helsinki, Finland  
Jussi.Paatero@fmi.fi

<sup>2</sup>Norwegian Institute for Air Research, The Polar Environmental Centre,  
NO-9296 Tromsø, Norway  
kjh@nilu.no

### INTRODUCTION

World Meteorological Organization's (WMO) Global Atmosphere Watch (GAW) programme operates a monitoring network consisting of 22 global stations and ca 300 regional stations. Global stations are situated in remote locations, have very low (background) levels of pollutants that are representative of large geographical areas, and continuously measure a broad range of atmospheric parameters. Finnish Meteorological Institute's (FMI) measuring stations at Pallas and Sodankylä in northern Finland together form one of these global stations. The Mt. Zeppelin GAW station is located at Ny-Ålesund, Svalbard some 1000 km north of Pallas.

Natural airborne radionuclides radon-222 (<sup>222</sup>Rn), lead-210 (<sup>210</sup>Pb) and beryllium-7 (<sup>7</sup>Be) are part of the GAW monitoring programme because they can be used as tracers in atmospheric studies. The monitoring of these nuclides carried out at Pallas-Sodankylä and Mt. Zeppelin stations is presented in the following.

### STATIONS AND MONITORING METHODS

Pallas is in subarctic region at the northernmost limit of the northern boreal forest zone. Surrounding forest is mixed pine, spruce and birch (*Hatakka et al.*, 2003). The area has five separate stations within 12 km of each other. Two of these stations are used for <sup>222</sup>Rn measurements. Sammaltunturi (67°58'N, 24°07'E) is the main station at Pallas with the largest programme. The station resides on a top of a fjeld at an elevation of 565 m above sea level (a.s.l.). The tree line is some 100 m below the station. The vegetation on the fjeld top is sparse, consisting mainly of low vascular plants, moss and lichen. Matorova station was built mainly due to the conditions being too harsh at Sammaltunturi during wintertime for filter sample collection. Matorova station (68°00'N, 24°14'E) lies six kilometres ENE of Sammaltunturi at an elevation of 340 m a.s.l. It is situated on top of a small hill covered by coniferous forest in a middle of ca 100 x 100 m clearing. The station is used mainly to collect deposition, gas and aerosol samples. Special attention was paid to the selection of building materials for the station, so that it would be suitable for collecting samples for trace metal, mercury and persistent organic pollutant analysis. In addition to GAW the station also participates in Arctic Monitoring and Assessment Programme (AMAP).

The FMI's Arctic Research Centre at Sodankylä (67°22'N, 26°39'E) is located in a subarctic pine forest some 100 km north of the Arctic Circle. The elevation of the station is 179 m above sea level. Upper-air soundings of meteorology, ozone, aerosol

particles and radioactivity, spectral UV-measurements, surface weather measurements, and air quality measurements, including carbon flux measurement with micrometeorological methods, are performed in the area. The distance between the Pallas and Sodankylä sites is 125 km.

The Mt. Zeppelin GAW station (78°58' N, 11°53' E) is located at Ny-Ålesund on the western coast of Spitsbergen, the largest island in the Svalbard archipelago. The station is located 474 m [a.s.l.]. Aerosol particles, mercury and particle-bound trace metals, persistent organic pollutants, and greenhouse and reactive gases are monitored at the station.

Radon-222 was measured via its beta active particle-bound progeny at the Sammaltunturi and Matorova stations with instruments based on collecting aerosol continuously onto a filter and measuring the beta activity on it. The hourly mean values are calculated by assuming that the activity on the filter is from short-lived  $^{222}\text{Rn}$  progeny, and that no artificial activity is present (*Paatero et al.*, 1998).

Lead-210 and  $^7\text{Be}$  was measured by collecting high-volume aerosol particle samples onto glass fibre filters (Munktell MGA) at Sodankylä and Mt. Zeppelin. Daily samples were collected at Sodankylä. At Mt. Zeppelin three samples per week were collected. Lead-210 was measured by alpha counting of the in-grown  $^{210}\text{Po}$ , and  $^7\text{Be}$  by semi-conductor gamma spectrometry (*Paatero and Hatakka*, 2000; *Paatero et al.*, 2003).

## RESULTS AND DISCUSSION

Usually the activity concentration of  $^{222}\text{Rn}$  is lower at Sammaltunturi than at Matorova due to the higher altitude of Sammaltunturi (Fig. 1). The diurnal variation of  $^{222}\text{Rn}$  concentration during different seasons is rather similar at both sites. Minimum concentrations are found in May--June, when the radon exhalation rate is at its minimum due to the wet snow cover and high water content of the surface soil, and the vertical mixing of the boundary layer is efficient due to the long daylight duration. In July and August the diurnal variation is at its maximum due to the simultaneous strong radon exhalation and frequent nocturnal surface inversions. Later in the autumn the diurnal variation decreases due to the decreasing amount of solar radiation causing vertical mixing. In winter the diurnal variation is almost non-existing and the concentration is at its maximum due to the stable conditions in the troposphere owing to the polar night. Later in the winter the increasing amount of solar radiation causes some diurnal variation again (*Hatakka et al.*, 2003).

The lowest  $^{210}\text{Pb}$  concentrations are found during summer both at Svalbard and in Finland (Fig. 2). The concentrations are lower at Svalbard than in Finland because Svalbard is further away from the source regions of  $^{210}\text{Pb}$ , i.e. continental areas. In winter the concentrations increase because of the lower mixing height and the small amount of precipitation causing wet deposition. The highest concentrations occur in March...April at Svalbard. This differs from the seasonal behaviour of  $^{210}\text{Pb}$  in Finland, where the highest concentrations are usually observed in February...March. This one-month difference between Svalbard and Finland may be related to the strength of solar radiation and its capability to cause vertical mixing of the air (*Paatero et al.*, 2003).

An air mass trajectory analysis of  $^7\text{Be}$  observed at Sodankylä indicates that the highest activity concentrations are associated with air masses coming from the Central Russia during anti-cyclonic conditions. High concentrations were encountered in spring also in air masses coming from the south-west. The latter cases were attributed to the transfer of stratospheric air masses into the troposphere along the polar front (Paatero and Hatakka, 2000).

## CONCLUSIONS

The demand of observation series on natural radionuclides in the air and deposition has gradually increased as their use as tracers and as a model validation tool has become more popular. The GAW stations of Pallas-Sodankylä and Mt. Zeppelin try to respond to this demand, and in the future the monitoring programmes will probably be expanded to airborne  $^7\text{Be}$  in Mt. Zeppelin and deposited  $^{210}\text{Pb}$  and  $^7\text{Be}$  at Pallas-Sodankylä.

## ACKNOWLEDGEMENTS

The authors would like to thank the staff of the Finnish Forest Research Institute and the Pallas-Ounastunturi National Park, and the Norwegian Polar Institute and Kings bay AS for the pleasant and ongoing cooperation. The financial support of the Ny-Ålesund LSF Project, European Community – Access to Research Infrastructure action of the Improving Human Potential Programme, for the  $^{210}\text{Pb}$  measurements at Mt. Zeppelin is gratefully acknowledged.

## REFERENCES

- Hatakka, J., Aalto, T., Aaltonen, V., Aurela, M., Hakola, H., Komppula, M., Laurila, T., Lihavainen, H., Paatero, J., Salminen, K. and Viisanen, Y., 2003. Overview of the atmospheric research activities and results at Pallas GAW station. *Boreal Environmental Research* 8, p. 365-383.
- Paatero, J. and Hatakka, J., 2000. Source Areas of Airborne  $^7\text{Be}$  and  $^{210}\text{Pb}$  Measured in Northern Finland. *Health Physics* 79, p. 691-696.
- Paatero, J., Hatakka, J. and Viisanen, Y., 1998. Concurrent Measurements of Airborne Radon-222, Lead-210 and Beryllium-7 at the Pallas-Sodankylä GAW Station, Northern Finland. *Reports No. 1998:1*. Finnish Meteorological Institute, Helsinki. 26 p.
- Paatero, J., Hatakka, J., Holmén, K., Eneroth, K. and Viisanen, Y., 2003. Lead-210 concentration in the air at Mt. Zeppelin, Ny-Ålesund, Svalbard. *Physics and Chemistry of the Earth* 28, p. 1175-1180.

Diurnal Variation of Radon-222 at Matorova, Pallas 1998-2001

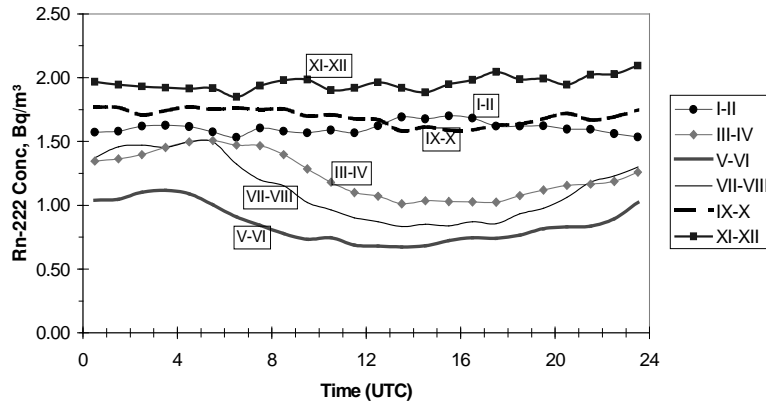

Diurnal Variation of Radon-222 at Sammaltunturi, Pallas 1997-2002

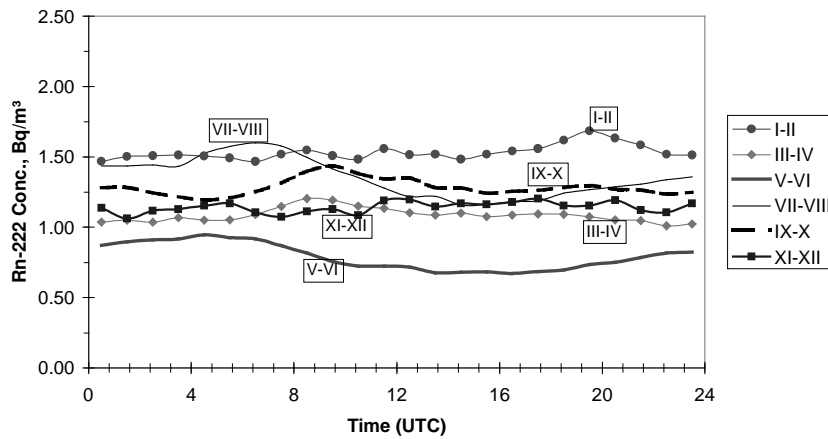

**Fig 1.** Average bimonthly diurnal variation of  $^{222}\text{Rn}$  concentration at Matorova and Sammaltunturi stations.

**Lead-210 in the air, Mt. Zeppelin, Ny-Ålesund, Svalbard 2001;  
Sodankylä and Nurmijärvi, monthly mean values 1991-2000**

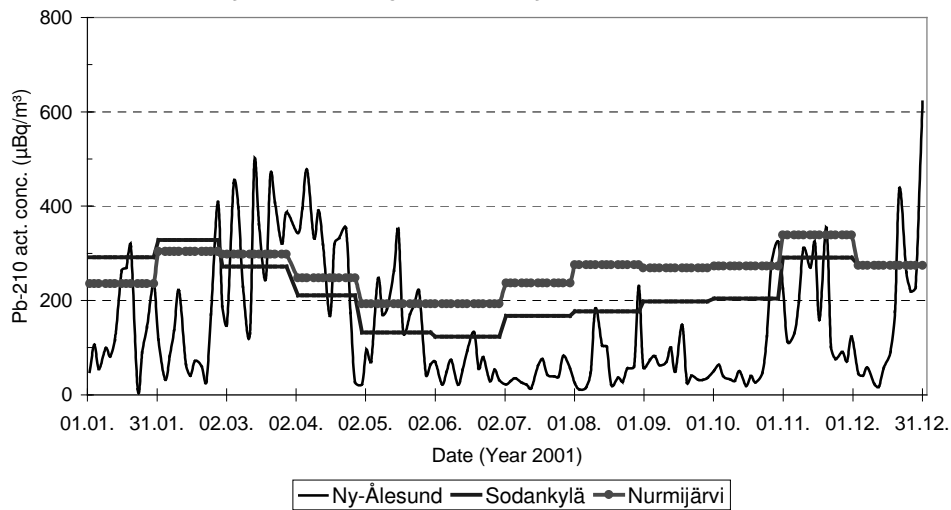

**Fig 2.**  $^{210}\text{Pb}$  activity concentration ( $\mu\text{Bq}/\text{m}^3$ ) in the air at Mt. Zeppelin GAW station, in 2001 and monthly mean values at Nurmijärvi and Sodankylä, Finland 1991-2000.

## CO<sub>2</sub> CONCENTRATIONS AND FLUXES AT PALLAS, FINLAND

Tuula Aalto, Juha Hatakka, Mika Aurela, Tuomas Laurila and Yrjö Viisanen  
Finnish Meteorological Institute, P.O.Box 503, FI-00101 Helsinki, Finland  
(email: Tuula.Aalto@fmi.fi)

### INTRODUCTION

CO<sub>2</sub> concentrations and ecosystem fluxes have been measured continuously in Pallas region for several years together with a variety of other trace gases, aerosols, precipitation chemistry and meteorological variables. Factors that affect the observed CO<sub>2</sub> concentration at Pallas include meteorological conditions, gas exchange by land and sea biota and anthropogenic influences. Although the location of Pallas is not coastal, lifetime of CO<sub>2</sub> is long and marine influences are possible due to long range transport from the Atlantic Ocean and Baltic Sea. During summer the sea acts as a sink due to the photochemical activity of the phytoplankton and cooling of surface waters brought to north by the North Atlantic Current leading to increase in CO<sub>2</sub> solubility. However, the immediate surroundings of Pallas belong to the boreal vegetation zone extending to Scandinavia and northern Russia. The vegetation acts as a photosynthetic carbon dioxide sink during daytime in summer and as plant and soil respiration induced source of CO<sub>2</sub> during night and winter. Anthropogenic emissions from the immediate surroundings of Pallas are negligible in comparison to the natural variation of CO<sub>2</sub> concentration. Variations in concentrations and fluxes and the causes for the variability have been studied by FMI, some results of which are shown here.

### MATERIALS AND METHODS

The CO<sub>2</sub> concentration measurement is located on top of a barren hill, 570m a.s.l. The hill is surrounded by a mixed-species boreal forest. The measurement procedure and processing of results follows the NOAA/CMDL methodology. The CO<sub>2</sub> concentration measurement system is described in detail in *Hatakka et al.* (2003). The fluxes are measured above old-growth Norway spruce (*Picea abies*) forest using eddy covariance measurement set-up similar to e.g. the one presented in *Aurela et al.* (2001). Three-dimensional back-trajectories were generated using a kinematic trajectory model FLEXTRA (e.g. *Stohl et al.*, 1999) which utilizes numerical meteorological data from an European Centre for Medium-Range Weather Forecasts (ECWMF) MARS database.

### RESULTS AND DISCUSSION

CO<sub>2</sub> concentrations at Pallas show increase during autumn and decrease during spring forming an oscillating pattern with increasing background trend (Fig. 1). The annual cycle of CO<sub>2</sub> shows concentration difference of about 19 ppm between the summer minimum and winter maximum. The diurnal cycle is most pronounced during July and August. The variation between daily minimum and maximum is about 5 ppm.

Backward trajectories have been analysed in order to determine the regions from where air masses mainly arrive to Pallas and which regions thus have the largest effect on the local air quality. A relatively unpolluted area surrounding the North Pole (north of  $71^{\circ}\text{N}$ ) is the most important source region, while south of  $55^{\circ}\text{N}$  contributes less than 10 percent to the arriving air masses. Continental and marine influences are close to equal importance (see also *Aalto et al.*, 2003). Trajectories have further been combined with concentration measurements and estimations have been made for source areas of high  $\text{CO}_2$  observed at Pallas (*Aalto et al.*, 2002). Source areas of carbon dioxide have been identified in Southern Finland and Central Europe during summer. During winter sources are more evenly distributed because soil respiration continues at low level and emissions due to heating are larger and more dispersed.

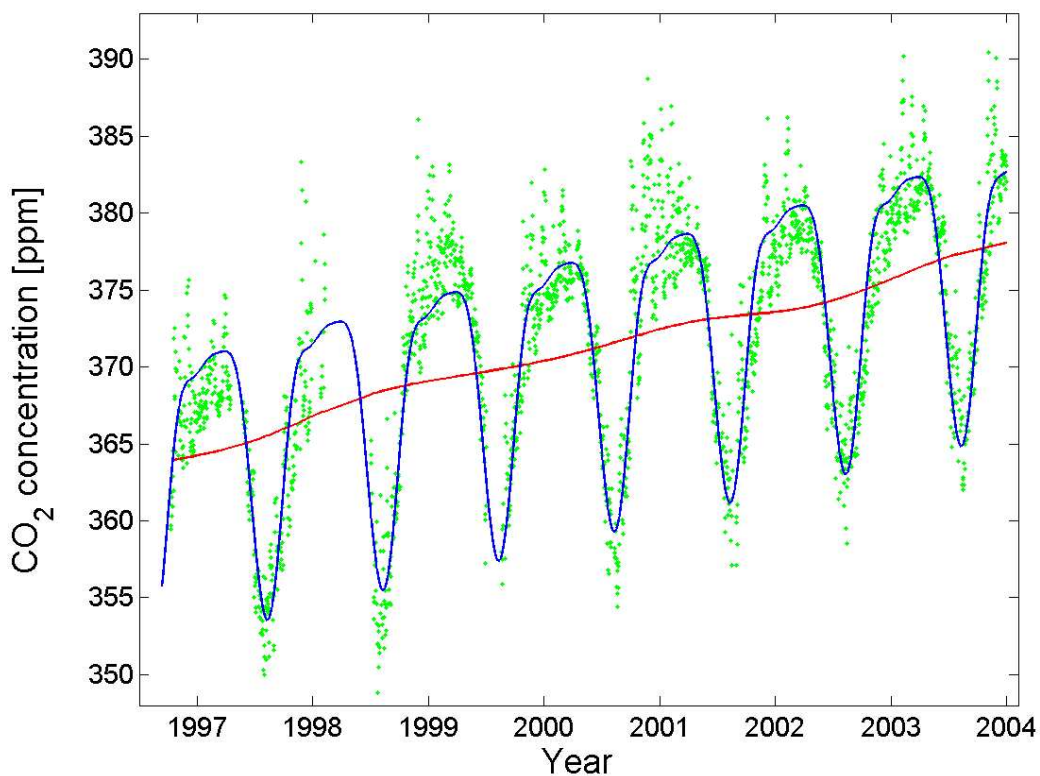

**Fig 1:** Timeseries of  $\text{CO}_2$  concentration at Pallas during years 1996-2003. Dots refer to daily means. Oscillating curve is a fit of the harmonic function to the daily means and line is the trend in concentration change.

Carbon dioxide exchange by the local forest ecosystem shows an annual cycle with net summertime uptake and weak carbon release during winter. The largest hourly exchange rates typically occur during the period from late June to late August. The variations in local fluxes and climatic conditions induce detectable variations also in  $\text{CO}_2$  concentration, but as the footprint or source region for concentration measurement is considerably larger than that for flux measurement, the observed concentration is more of a composite of local and long-range transported influences.



Global and regional carbon dioxide transport studies utilize the flux information as a boundary condition for the models (see e.g. *Aalto et al.*, 2004). Concentration measurements have also been used for estimations of carbon sinks in the inverse modeling. Concentration and flux measurements support each other in the research work concerning global carbon sinks and CO<sub>2</sub> transport, and the carbon-related research and research methodology at Pallas are under active development by FMI.

## REFERENCES

- Aalto, T., Hatakka, J., Paatero, J., Tuovinen, J.-P., Aurela, M., Laurila, T., Holmen, K., Trivett, N., and Viisanen, Y.*, 2002. Tropospheric carbon dioxide concentrations at a northern boreal site in Finland: Basic variations and source areas. *Tellus* 54B, p. 110-126.
- Aalto, T., Hatakka, J. and Viisanen, Y.* 2003. Influence of air mass source sector on variations in CO<sub>2</sub> mixing ratio at a boreal site in northern Finland. *Boreal Env. Res.* 8, p. 385–393.
- Aalto, T., Ciais, P., Chevillard, A. and Moulin, C.*, 2004. Optimal determination of the parameters controlling biospheric CO<sub>2</sub> fluxes over Europe using eddy covariance fluxes and satellite NDVI measurements. *Tellus* 56B, p. 93-104.
- Aurela, M., Tuovinen, J.-P. and Laurila, T.*, 2001. Net CO<sub>2</sub> exchange of a subarctic mountain birch ecosystem. *Theor. Appl. Clim.* 70, p.135-148.
- Hatakka, J., Aalto, T., Aaltonen, V., Aurela, M., Hakola, H., Komppula, M., Laurila, T., Lihavainen, H., Paatero, J., Salminen, K. and Viisanen, Y.*, 2003. Overview of atmospheric research activities and results at Pallas GAW station. *Boreal Environment Research* 8, p. 365-384.
- Stohl, A., Haimberger, L., Scheele, M.P. and Wernli, H.*, 1999. An intercomparison of results from three trajectory models. *Meteorol. Applications* 8, p. 127-135.

## VOC MEASUREMENTS IN PALLAS

Hannele Hakola and Heidi Hellén

Finnish Meteorological Institute, Air Quality Research, Sahaajankatu 20 E, FIN-00880  
Helsinki, Finland. e-mail: hannele.hakola@fmi.fi

### INTRODUCTION

Light molecular weight hydrocarbons ( $C_2$ - $C_6$ ) are common compounds in the atmosphere. Some of them exist in ppt levels also in very clean air. They are emitted to the air as a result of petrol exhaust, stationary combustion, gas leaks, solvent use etc. Some light hydrocarbons have also natural sources, isoprene is emitted in large quantities from several tree species (Kesselmeier et al., 2000 and the references therein) and ethene is a plant growth hormone. Some VOCs have considerable oceanic sources as well (Bonsang et al., 1991; Plass-Dülmer et al., 1993). In the atmosphere a reaction with hydroxyl radical is a main sink reaction for all hydrocarbons and a reaction with ozone is also an important sink for alkenes (Atkinson 1994). The reaction with hydroxyl radical can result in ozone production when enough nitrogen oxide is present to catalyze the reaction. Ozone formation takes place in various space- and timescales. The fast reacting compounds react close to source areas resulting in high ozone concentrations downwind, but slowly reacting compounds can be transported far particularly in winter when the amount of light, and hence hydroxyl radicals, is limited. During winter the VOCs accumulate in the northern latitudes, their concentration reaches a maximum during January-February and starts declining during spring when days get longer. Ozone formation can then occur in clean areas and high ozone concentrations have been measured at the high latitudes during spring. Ozone concentrations on a ground level have been increasing during the past decades and therefore the new European ozone directive (2002/3/EC) requires the member states of the European Union to measure the concentrations of ozone forming compounds.

Light hydrocarbons have been measured in Finland at two background stations Pallas and Utö since 1994. The stations are run by the Finnish Meteorological Institute (FMI). The Pallas station has been part of the Global Atmosphere Watch programme of the World Meteorological Organization since 1994. Pallas is in subarctic region at the northernmost limit of the northern boreal forest zone ( $67^{\circ} 58'N$ ,  $24^{\circ}07'E$ ). The station resides on a top of the fjeld at an elevation of 565 m above sea level. The vegetation on the fjeld top is sparse, consisting mainly of low vascular plants, moss and lichen. EMEP station Utö is a small, rocky island in the Baltic Sea ( $59^{\circ}47'N$ ,  $21^{\circ}23'E$ , 7 m above sea level) with very little vegetation. The VOC results from Utö and Pallas are reported to EMEP.

### SAMPLING AND ANALYSIS

At the background stations Utö and Pallas, the air samples are collected into evacuated stainless steel canisters twice a week, two canisters at a time using Teflon membrane pump. The urban samples are collected into canisters using 24-hour flow control restrictor.  $C_2$ - $C_6$  hydrocarbons were analyzed from canister samples using a gas chromatograph equipped with flame ionization detector (FID) and  $Al_2O_3/KCl$  PLOT column (50 m, i.d. 0.32 mm). Prior to analysis samples are passed through a stainless

steel tube (10cm\* 1/4'') filled with  $K_2CO_3$  and NaOH in order to dry them. Air samples are concentrated in two liquid nitrogen traps. The first trap is a stainless steel loop (1/8''\*125cm) filled with glass beads while the other one is a capillary trap. Calibration is performed using a gas-phase standard from NPL (National Physical Laboratory, UK) including 30 hydrocarbons at concentration levels of 1-10 ppb. The detection limits for individual compounds are varying from 3 to 11 ppt.

### THE CONCENTRATIONS OF VOCs AT THE BACKGROUND STATIONS

The VOCs are removed from the atmosphere mainly by a reaction with hydroxyl radicals produced in sunlight. In winter, the hydroxyl radical concentrations are extremely low (Hakola et al., 2003) and therefore also the atmospheric lifetimes of VOCs, in relation to OH radical reaction, are much longer in winter than in summer resulting in concentration maximum in winter. For example the lifetime of butane at Pallas is in January about 3.5 months and in July about 3.3 days. Figure 1 shows the annual cycle of some anthropogenic hydrocarbon (ethane, propane and butane) concentrations together with naturally produced isoprene concentrations from years 1999 to 2001. Isoprene is emitted from vegetation during growing season and therefore contrary to anthropogenic hydrocarbons, it has a summer maximum. The seasonal cycle of  $C_2$ - $C_5$  hydrocarbons at Pallas have been studied by Laurila and Hakola (1996).

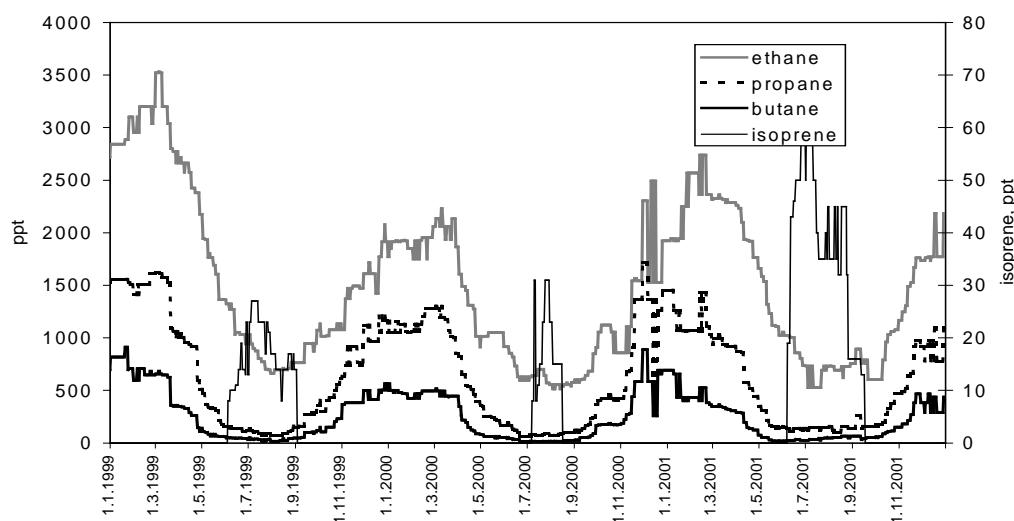
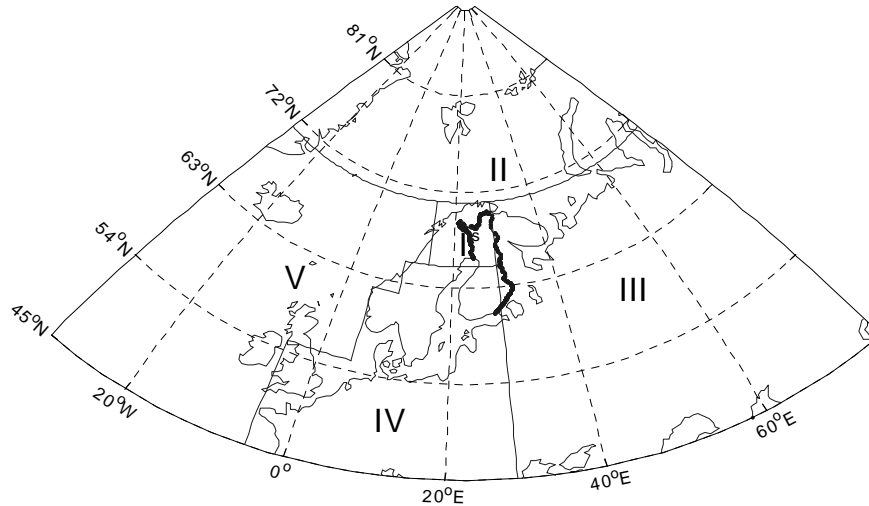

**Fig. 1.** 30-day running medians of VOC concentrations at Pallas.

Ethane is the most abundant VOC during all seasons but in summer it comprises more than half of the total amount of light VOCs due to its slow reaction rate with hydroxyl radical. The concentrations of the most reactive alkanes such as pentane and hexane are usually very low in summer.

The VOC concentrations were divided into four source areas according to the air mass origin. The three day back-trajectories were calculated for all winter measurements from

1994 until 2002. The trajectories were classified into four source areas; southern (Middle Europe), eastern (Russia), Arctic and Atlantic as shown in Fig. 2. Figure 3 shows that the highest concentrations were measured when the air was coming from the east. This is partly because the large eastern source areas, St Petersburg for example, are closer to the measuring sites than the European source areas. As expected the marine air masses coming from the Atlantic and Arctic areas are the cleanest.



**Fig. 2.** Different VOC source areas for trajectory analysis.

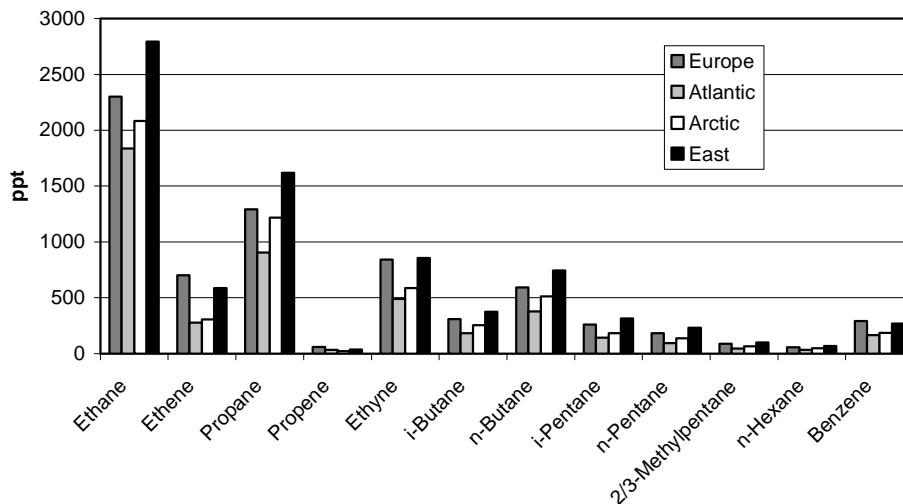

**Fig. 3.** The average winter concentrations measured in Pallas in different air masses.

No clear trends are observed for any of the compounds during the ten years of measurements. Perhaps more frequent sampling than two samples in a week would be needed for trend analysis. The data was too sparse for the trend analysis in different source areas.

## REFERENCES

- Atkinson R. (1994) Gas-phase tropospheric chemistry of organic compounds. *Journal of physical and chemical reference data. Monograph 2*, 216 pp.
- Bonsang B., Martin D., Lambert G., Kanakidou M., Le Roulley J.C. and Sennequier G. (1991) Vertical distribution of non methane hydrocarbons in the remote marine boundary layer. *J. Geophys. Res.*, 96, 7313-7324.
- Broadgate W., Liss P.S., and Penkett S. (1997) Seasonal emissions of isoprene and other reactive hydrocarbon gases from the ocean. *Geophys. Res. Lett.*, 24, 2675-2678.
- Finnlayson-Pitts B.J., Ezell M.J. and Pitts Jr. J.N. (1989) Formation of chemically active chlorine compounds by reactions of atmospheric NaCl particles with gaseous N<sub>2</sub>O<sub>5</sub> and ClONO<sub>2</sub>. *Nature*, 337, 241-244.
- Hakola H., V. Tarvainen, T. Laurila, V. Hiltunen, H. Hellén and P. Keronen, 2003. Seasonal variation of VOC concentrations above a boreal coniferous forest. *Atmospheric Environment* 37, 1623-1634.
- Hatakka J., Aalto T., Aaltonen V., Aurela M., Hakola H., Komppula M., Laurila T., Lihavainen H., Paatero J., Salminen K., and Viisanen Y. (2004) Overview of the atmospheric research activities and results at Pallas GAW station. *Boreal Env. Res.*, 8, 365-383.
- Kesselmeier J. and Staudt M., (1999) Biogenic volatile organic compounds (VOC): An overview on emission, physiology and ecology. *J. Atmos. Chem.*, 33, 23-88.
- Laurila Tuomas and Hannele Hakola (1996) Seasonal Cycle of C2-C5 hydrocarbons over the Baltic Sea and Northern Finland. *Atmospheric Environment*, 30, 1597-1607.
- Penkett S.A., Blake N.J., Lightman P., Marsh A.R.W. and Anzwyll P. (1993) The seasonal variation of nonmethane hydrocarbons in the free troposphere over the North Atlantic Ocean: Possible evidence for extensive reaction of hydrocarbons with the nitrate radical. *J. Geophys. Res.*, **98**, 2865-2885.
- Plass-Dülmer C., Khedim A., Koppmann R., Johnen F.J. and Rudolph J. (1993) Emissions of light nonmethane hydrocarbons from the Atlantic into the atmosphere. *Global Biogeochemical Cycles*, 7, 211-228.
- Saito T., Yokouchi Y., Kawamura K., 2000. Distributions of C2-C6 hydrocarbons over the western North Pacific and eastern Indian Ocean. *Atmospheric Environment* 34, 4373-4381.

## AEROSOL MEASUREMENTS AT PALLAS

Heikki Lihavainen, Veijo Aaltonen, Juha Hatakka, Mika Komppula, Jussi Paatero and  
Yrjö Viisanen  
Finnish Meteorological Institute, P.O.Box 503, FI-00101 Helsinki, Finland  
(email: heikki.lihavainen@fmi.fi)

### INTRODUCTION

Finnish Meteorological Institute's air quality measuring station at Pallas, northern Finland, has been part of the Global Atmosphere Watch programme of the World Meteorological Organization since 1994. Continuous measurements of aerosol particle characteristics were started on 1996. The present instrumentation includes continuous measurements of total number concentration, size distribution, scattering and backscattering coefficients and aerosol black carbon concentration. Also various trace gases and weather parameters are continuously monitored.

### SITE DESCRIPTION

Finnish Meteorological Institute's (FMI) measuring station at Pallas is part of the Pallas-Sodankylä Global Atmosphere Watch station located in Northern Finland. Aerosol measurements are done mostly at Sammaltunturi station (67°58' N, 24°07'E), which is the main station of the four measuring sites at Pallas, Fig 1. It is located inside the Pallas-Ounastunturi National Park. The distance to the nearest town, Muonio, with some 2500 inhabitants, is 19 km to the west. The area has no significant local or regional pollution sources. Closest major sources of pollutant are the smelters Nickel and Montshegorsk in Russia, located about 350 km away from Pallas, Nickel to the northeast and Montshegorsk to the east. The Sammaltunturi station resides on a top of the second southernmost fjeld in a 50 km long north and south chain of fjelds at an elevation of 565 m above sea level (a.s.l.). The vegetation on the fjeld top is sparse, consisting mainly of low vascular plants, moss and lichen. Pallas is in subarctic region at the northernmost limit of the northern boreal forest zone. The timberline lies about 100 m below the Sammaltunturi station. The surrounding forest is mixed pine, spruce and birch. The highest fjelds in the chain are 600 to 800 m a.s.l. Otherwise the region is hilly (250- 400 m a.s.l.), forested and partly swampy with some rather large lakes (ca 250 m a.s.l.). More detailed description on the site is given in *Hatakka et al.* (2003).

### INSTRUMENTATION

The aerosol sample is taken about 10 m above the ground surface. Large particles and cloud droplets are removed from the flow by impaction prior the sample is taken inside the station building. The cut-off size for large particles is about 5-10  $\mu\text{m}$ , depending slightly on wind speed.

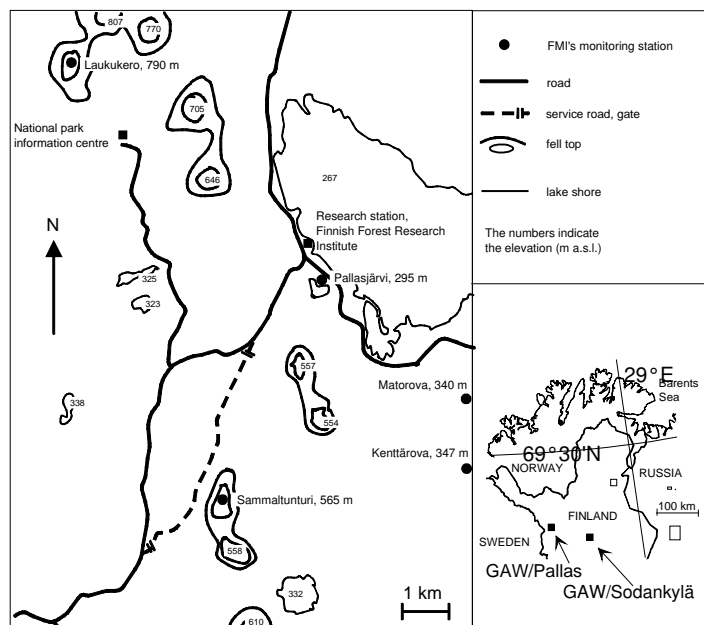

**Fig. 1.** Location of measurement site Pallas, Finland

Total aerosol number concentration is measured with a Condensation Particle Counter (CPC, TSI model 3010), which measures aerosol particles larger than 10 nm. Number concentration is also measured with a Laser Particle Counter (LPC, TSI 7550), which counts aerosol particles larger than 0.5  $\mu\text{m}$ .

Aerosol scattering and backscattering coefficients are measured with a three wavelength (450, 550 and 700 nm) integrating nephelometer, TSI 3563. The flow rate through the instrument is ca 25  $\text{m}^3 \text{h}^{-1}$ . Instrument is calibrated at least twice a year with pure  $\text{CO}_2$  and clean air.

Particle size distribution is measured with a Differential Mobility Particle Sizer (DMPS). DMPS is built up with 28-cm long Hauke-type differential mobility analyser with a closed loop sheath flow arrangement and a CPC (TSI model 3010). The measured particle size range is from 7 to 500 nm, which is divided into 30 discrete bins. A second DMPS system has been running at Matorova from April 2000 to February 2002, and at Laukukero from March 2002 to September 2003.

Aerosol black carbon is measured with an aethalometer (Magee Scientific). The instrument measures light absorption of aerosol collected onto a filter tape.

## OVERVIEW OF THE RESULTS

The average total aerosol number concentration at Sammaltunturi station is 800  $\text{cm}^{-3}$ , which is about half of what is observed forest area in southern Finland (*Komppula et al.* 2003a). The average of total scattering and backscattering coefficients of aerosol particles measured with an integrating nephelometer at wavelength 550 nm is about 5  $\text{Mm}^{-1}$  and 1  $\text{Mm}^{-1}$ , respectively and the average annual aerosol black carbon concentration is about 70  $\text{ng m}^{-3}$  (*Lihavainen et al.*, 2003). The scattering coefficient

correlates well with the accumulation mode and coarse mode particle concentration, as expected. Black carbon concentration follows quite closely scattering coefficient and particle concentration variations. Black carbon is a good indicator of an anthropogenic influence. Similar seasonal variation is observed in all three parameters. High values are found in late spring and summer, and the lowest values in autumn. For example the daily averages of total particle number concentration may rise at spring and summer over  $3000 \text{ cm}^{-3}$  whereas in winter may drop below  $100 \text{ cm}^{-3}$ . Total particle number concentration has a minimum in a winter whereas concentration of particles larger than  $0.5 \mu\text{m}$ , scattering coefficient and aerosol black carbon concentration has a minimum during late fall.

The properties of aerosol depends on the history of the air prior entering to Pallas. Both very clean and anthropogenically effected air masses are observed. Two different kind of size distributions are presented in Fig. 2. The size distribution with high aerosol number concentration has travelled through Kola Peninsula heavy industrial area before entering to Pallas area, the size distribution with much lower number concentration has arrived straight from Northern Atlantic.

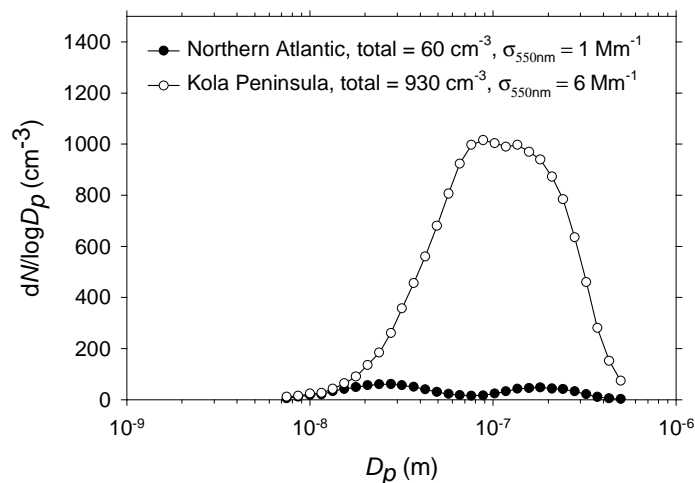

**Figure 2:** Two different kinds of size distributions observed at Pallas.

New particle formation events are observed during six months of the year, typically from April to September (*Komppula et al.*, 2003a, 2003b). Events are observed on about 10 % of the days during the all days and about 20 % on formation season days. All events are observed in clean air masses originating from Northern Atlantic or Arctic Ocean. The maximum number of events is found on April and May. Typically 1000-4000  $\text{cm}^{-3}$  new particles are formed in each event. In events where growth time of the formed particles over 12 hours is observed, secondary particle formation increases the number concentration of particles larger than 50 nm on the average by a factor of six, maximum increase being over a factor of 90. Clearly secondary particle formation is an important source of CNN in these air masses (*Lihavainen et al.*, 2003). Mechanism of formation and growth are not known but observations indicate that vapours responsible for formation may be different than responsible their growth to CCN size.



The Sammaltunturi station is inside clouds at least part of the day in about 10 % of all days in a year. Cloud scavenging of aerosol particles is observed throughout the year, mainly in fall when low clouds are more frequent. On the average particles having dry diameter larger than 80 nm (50 % activation efficiency) were activated (*Komppula et al.*, 2004 ). The activation diameter varies between 50 nm and 130 nm.

#### REFERENCES

*Hatakka, J., T. Aalto, V. Aaltonen, M. Aurela, H. Hakola, M. Komppula, T. Laurila, H. Lihavainen, J. Paatero, K. Salminen and Y. Viisanen*, 2003. Overview of the atmospheric research activities and results at Pallas GAW station, *Boreal Env. Res.* 8; 365-384,

*Komppula, M., H. Lihavainen, J. Hatakka, J. Paatero, P. Aalto, M. Kulmala, and Y. Viisanen*, 2003. Observations of new particle formation and size distributions at two different heights and surroundings in subarctic area in northern Finland, *J. Geophys. Res.*, 108; 4295

*Komppula, M., M. Dal Maso, H. Lihavainen, P. Aalto, M. Kulmala, and Y. Viisanen*, 2003b. Comparison of new particle formation at two locations in northern Finland, *Boreal Env. Res.*, 8; 395-404

*Komppula M., Lihavainen H., Kerminen V.-M., Kulmala M. and Viisanen Y.*, Measurements of cloud scavenging of aerosol particles in northern Finland, In Report Series in Aerosol Science N:o 68: Research Unit Physics, Chemistry and Biology of Atmospheric Composition and Climate Change: II Progress Report and Proceedings of Seminar in Helsinki 14.-16.4.2004 (edited by M. Kulmala, M. Salonen and Taina M. Ruuskanen), p. 115-118, 2004

*H. Lihavainen, V.-M Kerminen, M. Komppula, J. Hatakka, V. Aaltonen, M. Kulmala, and Y. Viisanen*, 2003. Production of 'potential' cloud condensation nuclei associated with atmospheric new-particle formation in northern Finland, *J. Geophys. Res.*, Vol. 108; 4782

## SIZE-SEGREGATED AEROSOL MEASUREMENTS IN SVALBARD

Kimmo Teinilä<sup>1</sup>, Risto Hillamo<sup>1</sup>, Veli-Matti Kerminen<sup>1</sup> and Harald Beine<sup>2</sup>

1. Finnish Meteorological Institute, Air Quality Research, Sahaajankatu 20E, 00880 Helsinki, Finland

(email: kimmo.teinila@fmi.fi)

2. C.N.R–Institute for Atmospheric Pollution, Via Salaria Km 29.3, CP10, I-00016 Monterotondo Scalo, Rome, Italy

### INTRODUCTION

Aerosol samples were collected in Ny-Ålesund, Svalbard during winter/spring 2001 as a part of the NICE (Nitrogen Cycle and Effects on the oxidation of atmospheric trace species at high latitudes) campaign. The aim of the project was to investigate the role of nitrogen species on the oxidation processes in Arctic and the distribution of nitrogen species between gas and particulate phase as well as on the snow surface. Our role was to investigate the concentration of ionic species in aerosol samples and to get information how these species are distributed over the particle size spectrum.

### MATERIALS AND METHODS

Aerosol samples were collected in Ny-Ålesund, Svalbard (78.54°N, 11.53°E) during two intensive field campaigns. The first campaign (“dark” campaign) was carried out between 21 February and 7 March and the second campaign (“light” campaign) took place between 23 April and 17 May. The measurement site was located at the sea-level, a few hundred meters outside the Ny-Ålesund community. Similar measurements were made also on the Zeppelin mountain (470 m a.s.l.).

Aerosol samples were collected using a small deposit area impactor (SDI, Maenhaut et al., 1996) and a virtual impactor (VI, Loo and Cork, 1988). The SDI has 12 collecting stages over the particle aerodynamic diameter range 0.045–20 µm. The flow rate of the SDI is 11 L min<sup>-1</sup>. The VI divides particles into two size fractions ( $D_p < 1.3$  µm,  $D_p > 1.3$  µm). The flow rate of the VI is 16.7 L min<sup>-1</sup>. In the SDI polycarbonate filters (poreless film from Nuclepore Inc., thickness 10 µm) was used as particle impaction substrates. The films were coated with Apiezon-L vacuum grease to prevent or to reduce the bounce-off of particles. The VI and SDI had similar inlets (University of Minnesota inlet, Liu and Pui, 1981) placed about 4.5 m above the snow surface. The inlets discriminated particles larger than 16 µm in the case of VI and particles larger than 20 µm in the case of the SDI.

The collected samples were analysed after the campaigns in Aerosol laboratory at FMI. The anions and cations were analysed simultaneously using two Dionex-500 ion chromatography systems. The analysed ions were Na<sup>+</sup>, NH<sub>4</sub><sup>+</sup>, K<sup>+</sup>, Mg<sup>2+</sup>, Ca<sup>2+</sup>, Cl<sup>-</sup>, NO<sub>3</sub><sup>-</sup>, SO<sub>4</sub><sup>2-</sup>, MSA<sup>-</sup> (methane sulphonate), oxalate, succinate and malonate.

## RESULTS AND DISCUSSION

Three particle types (anthropogenic sulphate, sea-salt and crustal particles) could be identified and their concentrations varied independently during the measurements. Nss-sulphate was the most abundant ion during both of the campaigns and it was mostly found in the submicron size range. The quite high nss-sulphate concentrations indicated that long-range transport was an important source of sulphate aerosol at the measurement site. The concentration of particulate ammonium was low which implicates that the air masses had not been in contact with gaseous ammonia sources.

Nearly all nitrate was found in the supermicron size range. This is expected since nitrate is not easily taken up by acidic particles. Nitrate was associated mostly with sea-salt particles. The mass size distributions showed that nitrate was also bound with calcium, a crustal tracer, especially during the “light” campaign when the concentration of calcium increased. It seems that the locally produced crustal particles act as a sink for gaseous nitric acid. The importance of this sink increases when the production of crustal particles is increased during strong wind episodes.

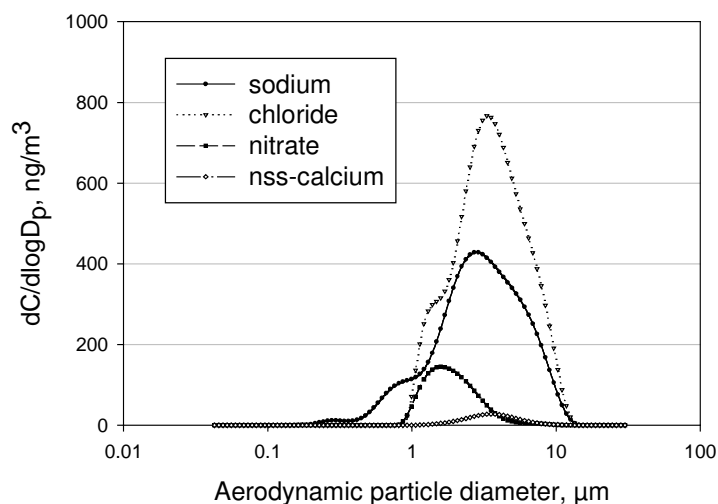

**Figure 1.** Mass size distributions of sodium, chloride, nitrate and nss-calcium.

## ACKNOWLEDGEMENTS

This work was funded by EU (NICE, EVK2-CT-1999-00029). All members of the NICE project are gratefully acknowledged.

## REFERENCES

- Liu, B. Y. and Pui, D. Y.*, 1981. Aerosol sampling inlets and inhalable particles. *Atmos. Environ.* 15, 585-600.
- Loo, B. W. and Cork, C. P.*, 1988. Development of high-efficiency virtual impactors. *Aerosol Science and Technology* 9, 167-176.
- Maenhaut, W., Hillamo, R., Mäkelä T., Jaffrezo J.-L., Bergin M. H. and Davidson D. I.*, 1996. A new cascade impactor for aerosol sampling with subsequent PIXE analysis. *Nuclear Instruments and Methods B* 109/110, 482-487.

## **EMEP'S CONTRIBUTION TO A MULTI-PURPOSE MONITORING CAPACITY FOR ATMOSPHERIC COMPOSITION IN EUROPE - COLLABORATION WITH WMO-GAW AND OTHERS ON JOINT SUPERSITES**

Kjetil Tørseth  
NILU/EMEP-CCC, Postboks 100, N-2027 Kjeller, Norway

### **ABSTRACT**

Long term operation of sites for measurements of atmospheric physical properties and chemical composition is essential for improving our understanding of processes, the development of models on which abatement policies can be based and to understand the changes occurring with time. These activities are deemed to require significant resources in both economic and competence terms, and also sets requirements towards data quality and comparability. Typically, long-term operation of sites can only be secured through legislation or international conventions, and it is in the interest of the parties to such frameworks that monitoring is cost efficient and has a wide use. This talk will present the monitoring strategy of EMEP. EMEP is the central programme providing resources for atmospheric chemistry measurements in Europe. Emphasis will be made on the differentiation of sites into various levels of ambition with respect to number of parameters monitored, as well as the linkages from the regional scale both towards the local as well as the hemispheric geographical scale. This includes also views on how new techniques like earth observation and chemical data assimilation can improve the current understanding. The talk will also discuss the linkages between EMEP and other relevant frameworks both within Europe and globally. Of particular interest is the interaction with the WMO-Global Atmosphere Watch programme, of which most EMEP sites support and in particular with respect to the more advanced measurement parameters. In the EMEP monitoring strategy, a clear identification of the objective to develop joint "supersites" between EMEP and GAW is given.

## AEROSOL RESEARCH AT ABOA, ANTARCTICA

Aki Virkkula<sup>1</sup>, Risto Hillamo<sup>1</sup>, Kimmo Teinilä<sup>1</sup>, Sanna Saarikoski<sup>1</sup>  
Ismo K. Koponen<sup>2</sup>, and Markku Kulmala<sup>2</sup>

1. Finnish Meteorological Institute, Air Quality Research, Sahaajankatu 20E, FIN-00880 Helsinki, Finland (email: [aki.virkkula@fmi.fi](mailto:aki.virkkula@fmi.fi))
2. Department of Atmospheric Sciences, Aerosol and Environmental Physics Laboratory, University of Helsinki, FIN-00014 Helsinki, Finland

### INTRODUCTION

The Finnish Antarctic research station Aboa (73°03'S, 13°25'W) is located 130 km from the shore on the nunatak Basen in the Vestfjella Mountains in Queen Maud Land. The Swedish research station Wasa is located only 200 meters from Aboa. Together the two stations form the Nordenskiöld Base Camp. The stations cooperate both in research and logistics. Since 1988 expeditions to Aboa have taken place almost annually. The research is funded by the Academy of Finland under the Finnish Antarctic Research Program (FINNARP). The coordination and logistics of FINNARP is taken care of by the Finnish Institute of Marine Research.

The aerosol research group of the Finnish Meteorological Institute (FMI) has conducted three measurement campaigns at Aboa, in 1997/98, 1999/2000, and 2000/2001. A brief description of these is given in this paper. In the first campaign there was no special room for atmospheric research only. Instead, the measurements were conducted in a tent, and the filter handling was done in the main building of Aboa without a proper clean room. If more measurements than those carried out during the first campaign were to be done, the infrastructure had to be changed. In order to create better facilities, a new laboratory, dedicated for atmospheric research only, was decided to be built at Aboa. It was designed by FMI aerosol research and built by Thermisol Finland and installed at Aboa in December 1999. The laboratory has so far been used during two expeditions, FINNARP 1999 and FINNARP 2000.

### MEASUREMENTS

In the first aerosol measurement campaign at Aboa aerosols were sampled using a two-stage filter sampler and a multi-stage impactor in order to determine size distributions of various ionic compounds in the aerosols. In addition, aerosol number concentrations were measured without any size information. Results of these measurements have been presented by *Kerminen et al.* (2000) and *Teinilä et al.* (2000). The following two campaigns in 1999/2000 and 2000/2001 were conducted in cooperation with FMI and Aerosol and Environmental Physics Laboratory of University of Helsinki. The new laboratory container made it possible to measure more parameters than during the first campaign. The measured parameters included number concentrations, number size distributions, light scattering coefficients, aerosol optical depth, both bulk and size-fractionated aerosol chemical composition, <sup>210</sup>Pb activity concentrations, and ozone concentrations. In January 2000 aerosol dry deposition measurements were conducted by the University of Stockholm close to the laboratory container with eddy-covariance method. Number concentrations, number size distributions, and weather data measured

in the laboratory container were used for the interpretation of the deposition data (Grönlund *et al.*, 2002).

One of the most interesting results of the campaigns so far is that we observed high concentrations of freshly-formed small particles during a few particle formation events. They were associated with air masses coming from the coast. In the air masses coming from the center of the continent the number size distribution was very stable with an Aitken and accumulation mode (Figure 1) (Koponen *et al.*, 2003). Other results have been presented, e.g., by Koponen *et al.* (2002, 2003) and Virkkula *et al.* (2002).

Aerosol deposition has also been studied in cooperation with the snow research group of the University of Helsinki Geophysics department during FINNARP 1999, 2000, and 2003 expeditions. Surface snow samples have been taken along a transect from the seaward edge of the ice shelf to the Antarctic plateau and analysed for the major inorganic species at FMI. The concentrations have been compared with the concentrations in aerosols at Aboa. The results are used for estimating the contribution of dry deposition to total deposition.

### NEW DEVELOPMENTS

So far only summertime measurements have been conducted at Aboa because it is only a seasonal station and there have not been instruments that would run unattended and without 220 V AC power. The influence of season, weather and solar radiation on particle formation should be studied with year-round measurements. In summer 2003/2004 the first step towards automatic continuous measurements was taken. The FMI aerosol research group built an automatic system for measuring number concentrations with low power consumption in cooperation with the Aerosol and Environmental Physics Laboratory of University of Helsinki. The instruments run on solar power, wind power, and attached batteries that provide 24 V DC voltage.

The aerosol measurement system was installed together with a new automatic weather station (WMO 89014, 73 03'S, 13 25'W ) in the aerosol research laboratory in November 2003. The laboratory container was also moved to a new location, on top of a hill about 200 m from Aboa main building (Figure 2). The weather station includes a Vaisala Milos 500 AWS data logging system where the following sensors are connected: wind direction and velocity: Thies CLIMA Ultrasonic Anemometer 2D, 12m above ground, 489m ASL, Relative humidity: Vaisala, HMP 45D, 2m above ground; temperature: Pentronic Pt-100, 2m above ground; pressure: Vaisala PTB220, 1.7m above ground, 478.7m ASL, global radiation: Kipp&Zonen CM11, heated, 4m above ground, UVB-radiation: Solar Light CO.inc, model 501A, 4m above ground, ground temperature: 4 Pentronic Pt-100 sensors at -2cm, -10cm, -30cm and -60cm. The particle counter system described above transfers data automatically to the Milos 500 once an hour. The weather and particle data are transferred via satellite to FMI data bases and the weather data from FMI to the WMO global Telecommunication System (GTS) satellite data exchange system automatically every 3 hours.

### FUTURE PLANS

The experiences gained from the automatic measurements so far will be used for improving them and adding more parameters. Also campaigns such as those conducted so far are planned, with additional parameters to be measured. The cooperation of FMI

aerosol research with the Aerosol and Environmental Physics Laboratory of University of Helsinki and the Geophysics Department of University of Helsinki will be continued. New cooperative projects with Swedish institutes are also planned.

#### ACKNOWLEDGEMENTS

The project was funded by the Academy of Finland (Finnish Antarctic Research Program, 'Aerosols in Antarctica', contracts no. 43928 and 53669).

#### REFERENCES

Grönlund, A., Nilsson, D., Koponen, I.K., Virkkula, A., and Hansson, M., 2002. Aerosol dry deposition measured with eddy-covariance technique at Wasa and Aboa, Dronning Maud Land, Antarctica, *Ann. Glaciology* 35A: p. 355-361.

Kerminen, V.-M., Teinilä, K. and Hillamo, R., 2000. Chemistry of sea-salt particles in the summer Antarctic atmosphere. *Atmos. Environ.* 34: p.2817-2825.

Teinilä, K., Kerminen, V.-M., and Hillamo, R., 2000. A study of size-segregated aerosol chemistry in the Antarctic atmosphere. *J. Geophys. Res.* 105: p. 3893-3904.

Koponen, I.K., Virkkula, A., Hillamo, R., Kerminen, V-M, and Kulmala, M., 2002: Number size distributions and concentrations of marine aerosols: Observations during a cruise between the English Channel and the coast of Antarctica. *J. Geophys. Res.* 107(D24): 4753, DOI: 10.1029/2002JD002533

Koponen, I.K., Virkkula, A., Hillamo, R., Kerminen, V-M, and Kulmala, M., 2003: Number size distributions and concentrations of the continental summer aerosols in Queen Maud Land, Antarctica. *J. Geophys. Res.* 108(D18): 4587, DOI:10.1029/2003JD003614.

Virkkula, A., Teinilä, K., Viidanoja, J., Karonen, J., Paatero, J., Hillamo, R., Kerminen, V.-M., Koponen, I.K., and Kulmala, M., 2002: Chemical composition of marine boundary layer aerosol over the Atlantic Ocean between English Channel and Antarctica, during the FINNARP-1999/2000 expedition, *Proc. of 8th European Symposium on the Physico-Chemical Behaviour of Atmospheric Pollutants, Torino 2001*, J.Hjorth, F.Raes and G.Angeletti Eds., CD and internet: [www.ies.jrc.cec.eu.int/Units/cc/events/torino2001/torinocd/Documents/Marine/MP12.htm](http://www.ies.jrc.cec.eu.int/Units/cc/events/torino2001/torinocd/Documents/Marine/MP12.htm)

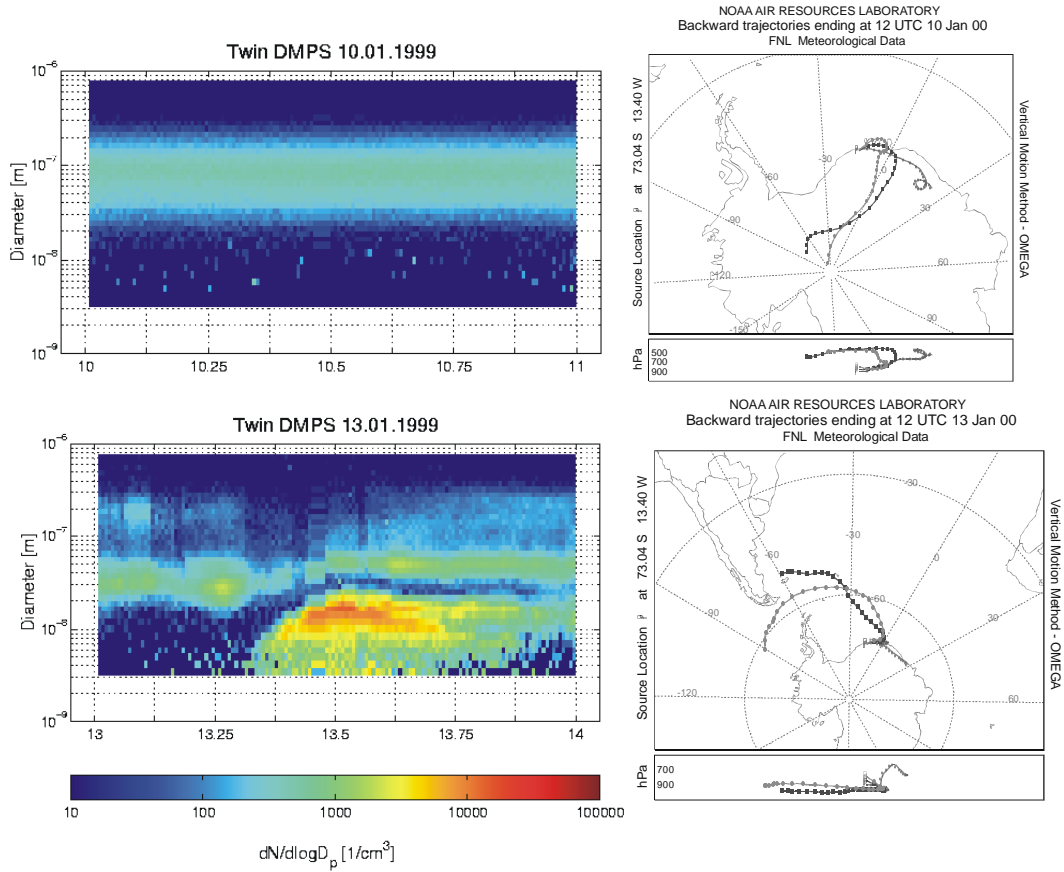

**Figure 1.** Number size distribution time series of aerosols arriving from the centre of the continent (upper panel) and from the ocean (lower panel), and the associated backtrajectories (*Koponen et al., 2003*).

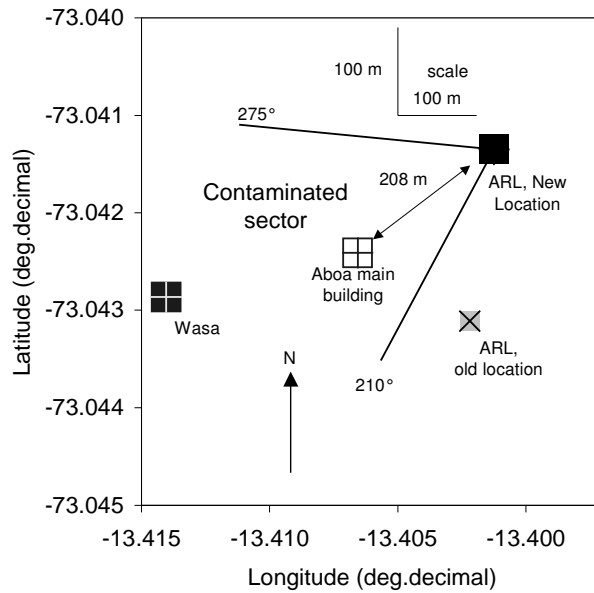

**Figure 2.** Location of Aboa and Wasa and the new and old location of the aerosol research laboratory (ARL), and the contamination sector.



# ATMOSPHERIC MEASUREMENTS IN KIRUNA AND WASA ANTARCTICA – PRESENT STATUS AND IDEAS FOR THE FUTURE

Uwe Raffalski and Sheila Kirkwood

Swedish Institute of Space Physics, P.O.Box 812, S- 98128 Kiruna, Sweden

(email: Uwe.Raffalski@irf.se

Sheila.Kirkwood@irf.se

<http://www.irf.se/MRIatmos>)

## INTRODUCTION

The focus of this article is to present the atmospheric research conducted at IRF and in collaboration with other institutes. A relatively wide range of scientific objectives is covered by measurements performed at IRF or by IRF scientists. Therefore the methods deployed for the investigations vary quite much. We choose to present them divided into two parts which can roughly be described as addressing the physical and the chemical properties of the atmosphere.

## INVESTIGATION OF THE PHYSICAL PROPERTIES OF THE ATMOSPHERE

The ESRAD Mesosphere - Stratosphere - Troposphere radar (MST-radar, 1996 - ...) is located at the near-by European rocket launch range Esrange (67°53'N 21°06'E). The antenna field is a 12x12 array of 5-element yagis, each ca. 6 m high 3 m across (Fig. 1). Using radar echoes from atmospheric turbulence, wind measurements can be obtained for heights ca. 1 - 12 km. Echoes from charged aerosol layers also give wind measurements close to the mesopause, i.e. 80-90 km, in summer and occasionally between 50 – 80 km in winter. Tropospheric winds and static stability profiles can be retrieved for the lower altitude regime. In addition it is possible to study the morphology of the tropopause at ca. 8 km height. Mesospheric winds and aerosol is obtained from the higher altitude regime together with other distinct echo structures such as PMSE (polar mesosphere summer echoes) at ca. 85 km, and as yet poorly understood layers between 50 and 80 km which sometimes can be seen in winter. Winds between 90 and 110 km can be measured by ESRAD using meteor echoes, but this is usually done by a separate radar at Esrange (SkiYmet)

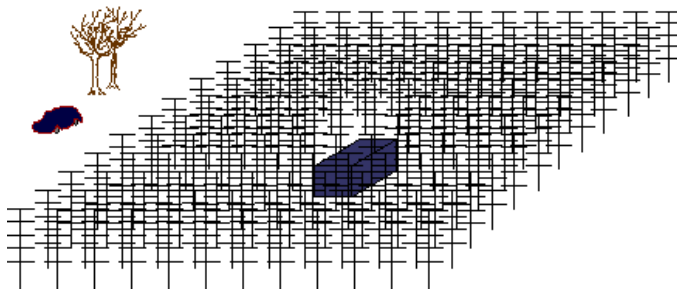

**Figure 1.** Antenna field of the ESRAD radar at Esrange, 67°53'N 21°06'E.

ESRAD is operated continuously, cycling between modes optimized for troposphere, stratosphere, or mesosphere. Real-time winds are available to approved users. Data plots are publically available on the web site and the digital data archive is also available to interested scientists on a cooperative basis with scientists at Swedish Institute of Space Physics (IRF-K) or the Meteorological Institute of Stockholm University (MISU).

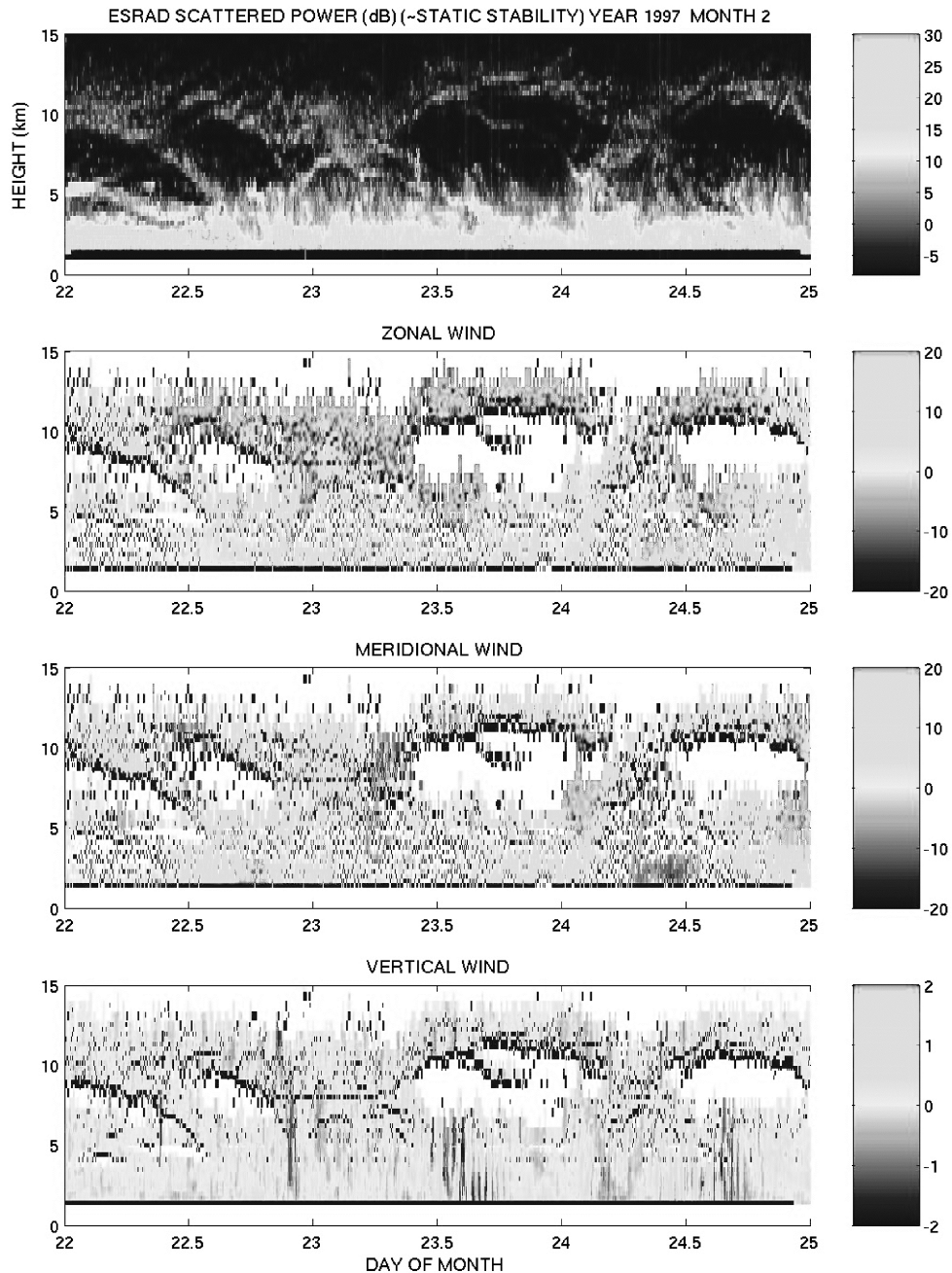

**Figure 2.** Typical wind and static stability profiles for 3 days of observations with ESRAD.

With help of the European Incoherent Scatter facility (Eiscat) observations of microphysics of dusty plasma are performed. IRF scientists are conducting experiments where they use the power of the emitted radiation for heating of the mesosphere and observe the effect on the processes in the mesosphere. For this experiment the VHF radar in Tromsø is used.

A long wire antenna is installed at Esrange for the observation of the Earth's global electrical circuit. The fair weather current and its interaction with geomagnetic phenomena, such as, for example, a magnetic substorms is investigated. This antenna has a length of nearly 100 m, and the near ground vertical current is recorded with a time resolution of 10 seconds. A second antenna at a distance of 30 km is used for comparison and possible separation of meteorological effects.

The Lidar instrument at IRF made its first atmospheric observations in February 2004. It is designed for aerosol in the troposphere and lower stratosphere. Additionally it will provide information about density and temperature of the atmosphere. Finally it will also measure ozone in the troposphere and lower stratosphere.

#### INVESTIGATION OF THE CHEMICAL PROPERTIES OF THE ATMOSPHERE

The new Swedish millimetre wave radiometer has been built in collaboration with the millimetre wave group at the Institute of Meteorology and Climate Research, Forschungszentrum und Universität Karlsruhe (*Kopp et al.*, 2003). The instrument is designed for the observation of thermal emission lines of stratospheric trace gases between 195 and 225 GHz. Within these 30 GHz there are signatures of stratospheric O<sub>3</sub>, ClO, N<sub>2</sub>O and HNO<sub>3</sub>. Measurements are performed in a continuous mode 24 hours a day throughout the year since Jan 2002. Additionally, measurements of the tropospheric transmission and tropospheric water vapour columns are routinely carried out. As an example, ozone measurements of the year 2003 are presented in Fig 3. From the measurements an ozone loss of about 20 to 30% (depending on altitude) could be calculated (*Raffalski et al.*, 2004).

The Fourier Transform InfraRed (FTIR) instrument is operated in Kiruna, again in collaboration with the Institute of Meteorology and Climate Research, Forschungszentrum und Universität Karlsruhe (*Blumenstock et al.*, 2002). This instrument measures solar absorption spectra of about 20 different trace gases. Besides ozone it measures important species involved in the ozone chemistry. Furthermore the FTIR detects CO<sub>2</sub>, Methane and water vapour isotopes, the most important greenhouse gases. Concerning ozone measurements the FTIR and the millimetre wave radiometer can complement each other due to the overlapping altitude range of the two instruments (see Figure 4).

The Differential Optical Absorption Spectrograph (DOAS) is operated in collaboration with Heidelberg University. It is the third optical instrument measuring ozone. But moreover it can detect BrO which may have an important role in the ozone chemistry in the future. The DOAS instrument can also be used for the detection of polar stratospheric clouds. These clouds at medium altitude (20 to 25 km) have an important influence on the winter ozone depletion over the poles. Since PSC are small particles they can also be identified by Lidar and Esrad radar.

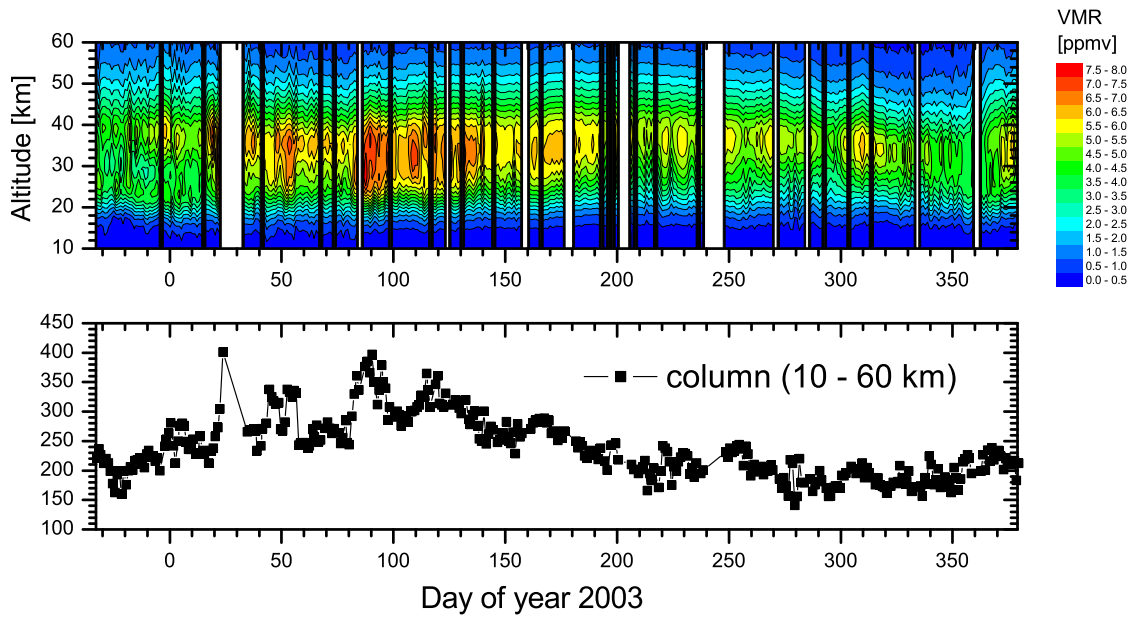

**Figure 3.** The evolution of ozone during 2003 and 2004. The upper panel shows the time series of ozone volume mixing ratio (vmr) profiles. Longer periods with no data due to technical problems have been kept blank. The middle panel shows the stratospheric ozone column above an altitude of 10 km.

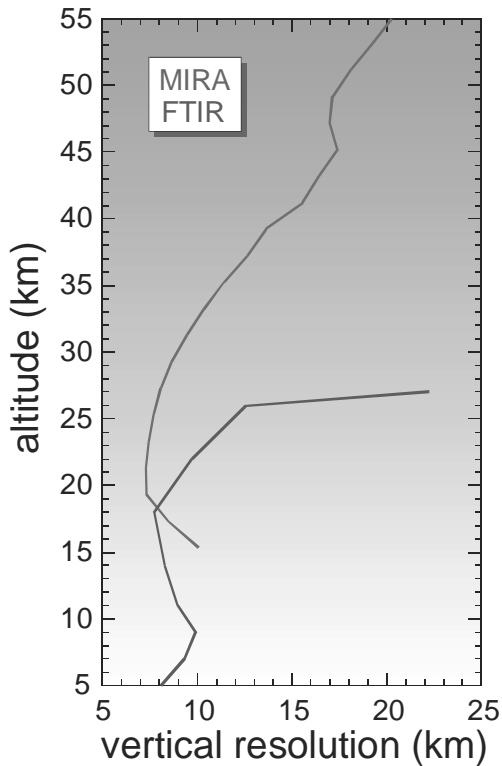

**Figure 4.** Vertical coverage and resolution of mm-wave radiometer (red) and FTIR (green).

## SCIENTIFIC OBJECTIVES AND PLANS FOR ANTARCTICA

During the Antarctic summer periods in 2001/2002, 2002/2003 and 2003/2004 a long wire antenna (similar to that at ESRAD) has been installed at the Swedish Antarctic station Wasa. Effects such as a disturbance of the global electric circuit due to solar storms are expected to be stronger around the poles.

Trace gas measurements at Wasa are planned for the Antarctic summer 2004/05. A DOAS instrument similar to the one at IRF, will be installed at the station for continuous measurements of mainly ozone and bromine oxide. Simultaneous measurements with the close by German Georg von Neumayer-Station offers a great potential for studies of both, the chemical evolution in time as well as spatial transport processes of tropospheric trace gases. The fate of air masses passing both stations can be studied in detail.

An atmospheric radar is planned at Wasa for summer 2006/2007, if funding for the hardware can be raised. In principle the same measurements as with ESRAD could then be conducted at Wasa during the Antarctic summer months.



**Figure 5:** The long antenna at the Antarctic station Wasa.

## SUMMARY AND CONCLUSIONS

We have presented the range of measurements performed at IRF. The atmospheric research at IRF is a comparably new scientific field with apparently isolated topics for the time being. The future task will be to make use of synergetic effects and to enhance the scientific value of the individual instrument by addressing common scientific questions.

## ACKNOWLEDGEMENTS

We would like to thank G. Kopp at the Institute of Meteorology and Climate Research, Forschungszentrum und Universität Karlsruhe for processing the data of the FTIR and the millimetre wave radiometer. The ESRAD radar is jointly operated by Swedish Institute of Space Physics and Swedish Space Corporation, Esrange. Sven Lidström of Polarforskningssekretariat has done most of the work of collecting atmospheric-current measurements at Wasa.

## REFERENCES

A full list of publications can be found at : <http://www.irf.se/MRIatmos>

*Kirkwood, S. , V. Barabash, E. Belova, H. Nilsson, N. Rao.,K. Stebel, A. Osepian, Phillip B. Chilson, 2002. Polar Mesosphere Winter Echoes during Solar Proton Events, Advances in Polar Upper Atmosphere Research, 16, 111-125.*

*Kirkwood, S., and K. Stebel, 2003. Influence of planetary waves on noctilucent cloud occurrence over NW Europe, J. Geophys. Res., 108(D8), 8440, doi:10.1029/2002JD002356.*

*Narayana Rao, T., S. Kirkwood, Johan Arvelius, Peter von der Gathen, and Rigel Kivi,2003. Climatology of UTLS Ozone and the ratio of Ozone and Potential Vorticity over Northern Europe, accepted J. Geophys. Res. 108 (D22), doi:10.1029/2003JD003860.*

*Chilson, P., S. Kirkwood, A. Nilsson, 1999. The Esrange MST radar : a brief introduction and procedure for range validation using balloons, Radio Sci., 34, 427-436.*

*G. Kopp, H. Berg, Th. Blumenstock, H. Fischer, F. Hase, G. Hochschild, M. Höpfner, W. Kouker, Th. Reddmann, R. Ruhnke, U. Raffalski, Y. Kondo, 2003. Evolution of ozone and ozone related species over Kiruna during the THESEO 2000 - SOLVE campaign retrieved from ground-based millimeter wave and infrared observations, Journal of Geophysical Research, Vol. 108, NO. D5, 8308, doi:10.1029/2001JD001064.*

*U. Raffalski, U., G. Hochschild, G. Kopp, and J. Urban, 2004. Evolution of stratospheric ozone during winter 2002/2003 as observed by a ground based millimetre wave radiometer at Kiruna, Sweden. submitted Atmospheric Chemistry and Physics.*

*T. Blumenstock, A. Griesfeller, F. Hase, M. Schneider, U. Raffalski, Y. Meijer, J.-C. Lambert, V. Soebijanta, Y. Calisesi, K. Stebel, V., H. Schets, I. Boyd, 2003. Comparison of MIPAS O3 profiles with ground-based measurements, Proceedings of the ENVISAT Validation Workshop, Frascati, Dec. 2002, ESA volume SP-531.*

## SMEAR I STATION IN VÄRRIÖ: ATMOSPHERIC AND BIOSPHERE-ATMOSPHERE INTERACTIONS MEASUREMENTS

Taina M. Ruuskanen<sup>1</sup>, Petri Keronen<sup>1</sup>, Pasi P. Aalto<sup>1</sup>, Erkki Siivola<sup>1</sup>, Toivo Pohja<sup>2</sup>,  
Pertti Hari<sup>3</sup>, Markku Kulmala<sup>1</sup>

1. University of Helsinki, Department of Physical Sciences, P.O. Box 64, FI-00014 University of Helsinki, Finland  
(email to corresponding author: Taina.Ruuskanen@helsinki.fi)
2. Hyytiälä Forestry Field Station, Hyytiäläntie 124, FI-35500 Korkeakoski, Finland
3. University of Helsinki, Department of Forest Ecology, P.O. Box 27, FI-00014 University of Helsinki, Finland

### INTRODUCTION

The SMEAR I (Station for Measuring Forest Ecosystem – Atmosphere Relation) station was established in 1991 in order to be able to measure mass and energy fluxes, biosphere-atmosphere interactions and atmospheric composition as well as ecosystem level processes like photosynthesis (*Hari et al.*, 1994). The long term measurements have been described by *Ahonen et al.* (1997) and *Ruuskanen et al.* (2003). The SMEAR I is an excellent example of natural laboratory, where clean arctic air is frequently changed to polluted plumes from Kola Peninsula. Together with the data from Pallas station the combined investigations have been shown to be very useful in Lagrangian studies like in new particle formation (*Komppula et al.*, 2003).

### STATION AND MEASUREMENT SET-UP

The Värriö measurement station SMEAR I (69°46'N, 29°35'E) (*Hari et al.* 1994) is located in Värriö nature park in eastern Lapland, less than ten kilometres from the border of Russia. The measurements were done from different heights of a measurement tower located on top of a hill 390 m above sea level (asl). The range of Värriö fjelds continue from north to south and the tower is surrounded by these fjelds. Most of the trees are about 50-years-old Scots pines (*Pinus Sylvestris* L.) and the height of the trees is about eight meters and the mean diameter approximately eight centimetres. The station is located below the alpine timberline (400 m asl) but some of the fjeld tops nearby are above it. The distance from the nearest small road to the station is approximately eight kilometres and from the nearest major road about 100 km. There are no towns or industry close by. Because there is practically no local pollution, transported pollutants are easy to detect. The nearest major pollution sources are Montchegorsk located 150 km east and Nickel located 190 km north from the station. Värriö measurement station and Montchegorsk are separated by a line of mountains on the Russian side, which ranges from north to south.

The measurements were done for concentrations of SO<sub>2</sub>, O<sub>3</sub> and NO<sub>x</sub> (trace gases), for number concentration of aerosol particles (14 nm --3 µm) and meteorological data such as temperature, humidity, radiation (PAR and global), pressure, wind direction and speed. Measurements of gas and aerosol particle concentrations and meteorological data were performed continuously at the measurement station. The operation of the system is

monitored and checked at least twice a week and the gas analysers were calibrated at least once a year.

The gases and aerosol particles were measured at different heights, inside the canopy and above it. All the data presented in this study are from measurements at the nine-meter level. The measurement cycle lasted 20 minutes for gases and particles and five minutes for meteorological data. One hour means were calculated from the measurements. Sampling lines were changed in the fall of 1993 from stainless steel to Teflon. There were only short time breaks for the monitoring system, usually in the late summer due to thunderstorms. O<sub>3</sub> measurement data from October 1993 to December 1994 was excluded from data analysis due to instrument malfunction.

Particle size distributions are measured with a DMPS-system (Differential Mobility Particle Sizer) consisting of two Vienna-type DMA:s (Differential Mobility Analyzers) and two CPC:s (Condensation Particle Counter; Models TSI 3010 and TSI 3025). The size range of the system is 3-600 nm, and it has a time resolution of ca. 10 minutes. The aerosol samples are taken at 2 m above ground level. A detailed description of the corresponding measurement system can be found in e.g in *Aalto et al.* (2001).

SO<sub>2</sub> was measured with a fluorescence analyser (Model 43S, Thermo Environmental Instruments, Inc., detection limit 0.1 ppb), O<sub>3</sub> with a photometric analyser (Model 49, Thermo Environmental Instruments, Inc., detection limit 1 ppb), and NO<sub>x</sub> with a chemiluminescence gas analyser (Model 42C TL, Environmental Instruments, Inc., detection limit 0.1 ppb). The chemiluminescence method was designed for NO<sub>x</sub> (NO + NO<sub>2</sub>), but the catalytic converter to measure NO<sub>2</sub> after reduction to NO partially reduces other oxidized nitrogen species, as well. Therefore the term NO<sub>x</sub>, used in this paper, refers to the detection of NO, NO<sub>2</sub> and partial detection of HONO, HNO<sub>3</sub>, PAN and some other organic nitrates. Aerosol particles were measured with a condensation particle counter (cpc; TSI 3760, detection limit 10<sup>-3</sup> particles cm<sup>-3</sup>). Calibration errors and losses in sampling lines, for example, account for measurement errors. The measurement system and instrumentation is presented in more detail by *Hari et al.* (1994) and *Ahonen et al.* (1997).

The photosynthesis is monitored with permanently installed chambers at the top of the pine trees by measuring changes in the CO<sub>2</sub> concentrations. The measurement starts at the late April or early May and ends late September or early October. The instrumentation is described in more detail by *Hari et al.* (1994).

## ON RESULTS

Examples of results are:

- long photosynthesis series, close relationship between photosynthesis and environment (*Hari and Mäkelä*, 2003)
- Lagrangian studies on aerosol formation (*Komppula et al.*, 2003, *Tunved et al.*, 2003)
- long continuous data sets on trace gases and aerosol concentrations (*Ruuskanen et al.*, 2003)



## REFERENCES

- Aalto P., Hämeri K., Becker E., Weber R., Salm J., Mäkelä J. M., Hoell C., O'Dowd C. D., Karlsson H., Hansson H.-C., Väkevü M., Koponen I. K., Buzorius, G. and Kulmala M., 2001. Physical characterization of aerosol particles during nucleation events. *Tellus*, 53B, 344-358.
- Ahonen T., Aalto P., Rannik Ü., Kulmala M., Nilsson E.D., Palmroth S., Ylitalo H. & Hari P., 1997. Variations and vertical profiles of trace gas and aerosol concentrations and CO<sub>2</sub> exchange in Eastern Lapland, *Atmos. Environ.* 31: 3351--3362.
- Hari P., Kulmala M., Pohja T., Lahti T., Siivola E., Palva L., Aalto P., Hämeri K., Vesala T., Luoma S. & Pulliainen E., 1994. Air pollution in Eastern Lapland: challenge for an environmental measurement station. *Silva Fennica* 28: 29--39.
- Hari P. and Mäkelä A., 2003. Annual pattern of photosynthesis in Scots pine in boreal zone, *Tree Physiology* 23:145-155.
- Komppula M., Dal Maso M., Lihavainen H., Aalto P.P., Kulmala M. and Viisanen Y., 2003. Comparison of new particle formation events at two locations in northern Finland, *Boreal Env. Res:* 8, 395-404.
- Tunved P., Hansson H.-C., Kulmala M., Aalto P., Viisanen Y., Karlsson H., Kristensson A., Swietlicki E., Dal Maso M., Ström J., Komppula M., 2003. One year boundary layer aerosol size distribution data from five Nordic background stations, *Atmos. Chem. Phys. Discuss.* 3, 2783-2833.
- Ruuskanen T.M., Reissell A., Keronen P., Aalto P.P., Laakso L., Grönholm T., Hari P. and Kulmala M., 2003. Atmospheric trace gas and aerosol particle concentration measurements in Eastern Lapland, Finland 1992-2001. *Boreal Env. Res:* 8: 335-349.

## **AEROSOLS IN LARGE-SCALE ATMOSPHERIC MODELS: FUTURE DIRECTIONS AND NEEDS**

Veli-Matti Kerminen and Hannele Korhonen  
Finnish Meteorological Institute, Climate and Global Change programme,  
Sahaajankatu 20E, FIN-00880 Helsinki, Finland  
(e-mail: veli-matti.kerminen@fmi.fi)

### INTRODUCTION

Large-scale atmospheric models range from regional air quality models to global chemical transport and/or climate models. The treatment of aerosol particles in such models was very crude in the past, as most models included only the sulfate aerosol or some other major aerosol type such as sea-salt or dust. The only predicted aerosol parameter in these models was the total mass concentration of each aerosol type. More recent models have aimed to predict the mass size distribution of relevant chemical components in the particulate phase.

The application of large-scale atmospheric models has shifted gradually from acid deposition and visibility studies toward investigating the climate change and various health effects caused by air pollution. As a result, new requirements for these models and their structures have appeared. In the following we will discuss briefly what this means in terms of treating aerosols in large-scale atmospheric models, and what implications this further has on doing aerosol measurements.

### TREATING AEROSOLS IN LARGE-SCALE ATMOSPHERIC MODELS

In response to the new requirements, large-scale atmospheric models should be able to predict the time evolution of the aerosol number size distribution as well as the chemical mass size distribution of the aerosol. This is not possible without 1) explicit incorporation of aerosol dynamical processes and their subgrid-scale parameterizations, 2) detailed representation of the aerosol size distribution, 3) more accurate treatment of emissions, and 4) better understanding on the chemistry and thermodynamic properties of most important aerosol precursor gases.

Aerosol dynamical processes have gradually become an essential component of large-scale air quality and climate models (*Schell et al.*, 2001; *Adams and Seinfeld*, 2002; *Kirkevåg and Iversen*, 2002). In this regard, perhaps the most challenging task is to simulate aerosol-cloud interactions, including cloud droplet activation, sulfate production by aqueous-phase chemistry, and competition between the wet removal by precipitation and cloud droplet evaporation. Suitable numerical techniques and parameterizations for taking into account the various aspects of aerosol-cloud interactions are already available (*Zhang et al.*, 2002; *Andronache*, 2003; *Kreidenweis et al.*, 2003; *Nenes and Seinfeld*, 2003), even though our overall understanding of these processes is yet far from complete.

A large fraction of submicron particulate matter is formed secondarily in the atmosphere, either by cloud processing or by gas-to-particle transfer of condensable vapours (*Derwent et al.*, 2003). The most important gases producing secondary particulate matter are sulfur dioxide, nitrogen oxides, ammonia and various semi-volatile organic compounds. While the emissions and/or chemistry of some of these compounds are relatively well quantified, large uncertainties exist with regard to many biogenic organic compounds (*Kesselmeier and Staudt*, 1999; *Atkinson and Arey*, 2003; *Boucher et al.*, 2003). Once the aerosol precursor vapour concentrations have been determined, their gas-to-particle transfer by condensation or cloud chemistry need to be treated explicitly in order to predict the aerosol mass or number size distribution (*Curciollo and Pandis*, 1997; *Capaldo et al.*, 2000). This is usually not possible without some compromise between the numerical accuracy and computational efficiency. Scientifically the most challenging issue is the modelling of the formation of secondary organic aerosol. This is made difficult by our improper understanding on the underlying gas-phase chemistry, the huge variety of organic compounds that can be present in the aerosol phase, and the lack of thermodynamic data necessary for describing the gas/particle partitioning of organic compounds (*Pun et al.*, 2003).

There are also aerosol processes that are irrelevant when predicting the aerosol mass size distribution but become essential when predicting the aerosol number size distribution. One of these is coagulation which is an important sink for the smallest atmospheric aerosol particles. Another such process is atmospheric new-particle formation, being an important source for the aerosol number in many different environments (*Kulmala et al.*, 2004). Including coagulation in atmospheric models is relatively straightforward, while the same is not true for new-particle formation. Reasons for this include the large scientific uncertainties and many technical difficulties involved in treating the complicated sequence of processes associated with new-particle formation in the models (*Kulmala*, 2003; *Kerminen et al.*, 2004).

A balance between computational efficiency and numerical accuracy plays a key role when choosing a representation of the particle size distribution in large-scale models. In this context, the most commonly used techniques are the modal (e.g. *Ghan et al.*, 2001) and the sectional approaches (e.g. *von Salzen et al.*, 2000). While the former typically requires less computing time, the latter offers a more flexible description of the particle size distribution and consistent way to treat new-particle formation, emissions and atmospheric transport between model grid cells. Furthermore, in recent years the development of modified sectional methods such as the moving center method and the hybrid method, which eliminate much of the numerical diffusion inherent to earlier techniques, has improved the computational viability of the sectional approach and thus made it more attractive for regional and global applications (*Korhonen et al.*, 2004). In order to limit the computational burden associated with the particle size distribution, most current large-scale models assume a homogeneous chemical composition within a particle mode/size section. While this assumption does not introduce serious errors in most simulated processes, in reality e.g. the number of activated cloud droplets is dependent not only on the size of the CCNs but also on their composition.

Perhaps the most challenging task in the future modeling is to combine the rather coarse spatial resolution of large-scale atmospheric models with the requirement that these models should be able to predict the chemical mass and number size distribution of the aerosol. This has large implications on how to deal with emissions and aerosol

dynamics in these models. For example, significant transformations in the aerosol size distribution takes place close to road traffic and in power plant plumes (*Seigneur et al.*, 1997; *Zhu et al.*, 2002; *Ketzel and Berkowicz*, 2004). These transformations cannot be simulated in large-scale models but need to be parameterized as part of the source term. Many aerosol dynamical processes such as new particle formation and growth as well as aerosol-cloud interactions take also place in a sub-grid scale. As a result, these processes need to be handled in a somewhat different way from what has typically been done in lagrangian box models or in high-resolution urban-scale models.

## IMPLICATIONS FOR AEROSOL MEASUREMENTS

Aerosol measurements are a necessary tool when testing the performance of existing large-scale models. In this context the role of various space-borne and ground-based remote sensing instruments has increased a lot during the recent years (see, e.g. *Conant et al.*, 2003; *Gonzalez et al.*, 2003), and without any doubts will continue to do so in the future. Available remote sensing techniques are, however, able to provide very limited amount of information about the aerosol size distribution and practically no information about the aerosol chemical composition. For this purpose, continuous measurements of aerosol physical and chemical properties in carefully-selected ground stations remain to be of high value in the future.

Field aerosol measurements are also needed in improving our understanding of key aerosol dynamical processes and in developing new model parameterizations for these processes. Of specific importance is to investigate aerosol-cloud interactions, both by continuous monitoring and by intensive field campaigns. Measurements related to atmospheric new-particle formation and secondary organic aerosol formation would also be valuable.

Finally, a combination of field and laboratory measurements is needed to better parameterize the major aerosol sources for atmospheric models. Among these are the natural sea-salt and dust emissions, as well as particulate emissions from the traffic, localised industrial complexes and different biomass burning sources.

## REFERENCES

- Adams, P. J. and Seinfeld, J. H.*, 2002. Predicting global aerosol size distributions in general circulation models. *J. Geophys. Res.* 107 (D19), doi: 10.1029/2001JD001010.
- Atkinson, R. and Arey, J.*, 2003. Gas-phase chemistry of biogenic volatile organic compounds: a review. *Atmos. Environ.* 32, Supplement 2, p. S197-S219.
- Boucher O., Moulin C., Belviso, S., Aumont O., Bopp, L., Cosme, E., Von Kuhlmann R., Lawrence, M. G., Pham, M., Reddy, M. S., Sciare, J. and Venkatamaran, C.*, 2003. DMS atmospheric concentrations and sulphate aerosol indirect radiative forcing: a sensitivity study to the DMS source representation and oxidation. *Atmos. Chem. Phys.* 3, p. 49-65.
- Andronache, C.*, 2003. Estimated variability of below cloud removal by rainfall for observed aerosol size distributions. *Atmos. Chem. Phys.* 3, p. 131-143.

Capaldo, K. P., Pilinis, C. and Pandis, S. N., 2000. A computationally efficient hybrid approach for dynamic gas/aerosol transfer in air quality models. *Atmos. Environ.* 34, p. 3617-3627.

Conant, W. C., Seinfeld, J. H., Wang, J., Carmichael, G. R., Tang, Y., Uno, I., Flatau, P. J., Markowicz, K. M., and Quinn, P. K., 2003. A model for the radiative forcing during ACE-Asia derived from CIRPAS Twin Otter and R/V *Ronald H. Brown* data and comparison with observations. *J. Geophys. Res.* 108 (D23), doi: 10.1029/2002JD003260.

Derwent, R. G., Collins, W. J., Jenkin, M. E., Johnson, C. E., and Stevenson, D. S., 2003. The global distribution of secondary particulate matter in a 3-D lagrangian chemistry transport model. *J. Atmos. Chem.* 44, p. 57-95.

Gonzales, C. R., Schaap, M., de Leeuw, G., Builjes, P. J. H. and van Loon, M., 2003. Spatial variation of aerosol properties over Europe derived from satellite observations and comparison with model calculations. *Atmos. Chem. Phys.* 3, p. 521-533.

Ghan, S. J., Easter, R. C., Chapman, E. G., Abdul-Razzak, H., Zhang, Y., Leung, L. R., Laulainen, N. S., Saylor, R. D. and Zaveri, R. A., 2001. A physically based estimate of radiative forcing by anthropogenic sulfate aerosol. *J. Geophys. Res.* 106, p. 5279-5293.

Gurciollo, C. S. and Pandis, S. N., 1997. Effect of composition variations in cloud droplet populations on aqueous-phase chemistry. *J. Geophys. Res.* 102, p. 9375-9385.

Kirkevåg, A. and Iversen, T., 2002. Global direct radiative forcing by process-parameterized aerosol optical properties. *J. Geophys. Res.* 107 (D20), doi: 10.1029/2001JD000886.

Kerminen, V.-M., Lehtinen, K. E. J., Anttila, T. and Kulmala, M., 2004. Dynamics of atmospheric nucleation mode particles: a timescale analysis. *Tellus* 56B, p. 135-146.

Kesselmeier, J. and Staudt, M., 1999. Biogenic volatile organic compounds (VOC): An overview on emissions, physiology and ecology. *J. Atmos. Chem.* 33, p. 23-88.

Ketzel, M. and Berkowicz, R., 2004. Modelling the fate of ultrafine particles from exhaust pipe to rural background: an analysis of time scales for dilution, coagulation and deposition. *Atmos. Environ.* 38, p. 2639-2652.

Korhonen, H., Lehtinen, K. E. J. and Kulmala, M., 2004. Aerosol dynamic model UHMA: Model development and validation. *Atmos. Chem. Phys. Discuss.* 4, p. 471-506.

Kreidenweis, S. M., Walcek, C. J., Feingold, G., Gong, W., Jacobson, M. Z., Kim, C.-H., Liu X., Penner, J. E., Nenes, A. and Seinfeld, J. H., 2003. Modification of aerosol mass and size distribution due to aqueous-phase SO<sub>2</sub> oxidation in clouds: Comparison of several models. *J. Geophys. Res.* 108 (D7), doi: 10.1029/2002JD002697.

Kulmala, M., 2003. How particles nucleate and grow. *Science* 302, p. 1000-1001.

Kulmala, M., Vehkamäki, H., Petäjä, T., Dal Maso, M., Lauri, A., Kerminen V.-M., Birmili, W. and McMurry, P. H., 2004. Formation and growth rates of ultrafine atmospheric particles: A review of observations. *J. Aerosol Sci.* 35, p. 143-176.

Nenes, A. and Seinfeld, J. H., 2003. Parameterization of cloud droplet formation in global climate models. *J. Geophys. Res.* 108 (D14), doi: 10.1029/2002JD002911.

Pun, B. K., Wu, S.-H., Seigneur, C. Seinfeld, J. H., Griffin, R. J. and Pandis, S. N., 2003. Uncertainties in modelling secondary organic aerosols: Three-dimensional modeling studies in Nashville/Western Tennessee. *Environ. Sci. Technol.* 37, p. 3647-3661.

Schell, B., Ackermann, I. J., Hass, H., Binkowski, F. S. and Ebel, A., 2001. Modeling the formation of secondary organic aerosol within a comprehensive air quality model system. *J. Geophys. Res.* 106, p. 28275-28293.

Seigneur, C., Wu, X. A., Constantinou, E., Gillespie, P., Bergstrom, R. W., Sykes, I., Venkataram, A. and Karamchandani, P., 1997. Formulation of a second-generation reactive plume and visibility model. *J. Air & Waste Manage. Assoc.* 47, p. 176-184.

Von Salzen, K., Leighton, H. G, Ariya, P. A., Barrie, L. A., Gong, S. L., Blanchet, J. P., Spacek, L., Lohmann, U. and Kleinman, L. I., 2000. Sensitivity of sulphate aerosol size distributions and CCN concentrations over North America to SO<sub>x</sub> emissions and H<sub>2</sub>O<sub>2</sub> concentrations, *J. Geophys. Res.* 105, p. 9741-9765.

Zhang, Y., Easter R. C., Ghan, S. J. and Abdul-Razzak, H., 2002. Impact of aerosol size representation on modelling aerosol-cloud interactions. *J. Geophys. Res.* 107 (D21), doi: 10.1029/2001JD001549.

Zhu, Y., Hinds, W. C., Kim, S., Shen, S. and Sioutas C., 2002. Study of ultrafine particles near a major highway with heavy-duty diesel traffic. *Atmos. Environ.* 36, 4323-4335.

## MULTI-SPECIES INTERPRETATION AT MT. ZEPPELIN – USING A TRAJECTORY CLIMATOLOGY

Kristina Eneroth<sup>1</sup> and Kim Holmén<sup>2</sup>

1. Finnish Meteorological Institute, Air Quality Research, Sahaajankatu 20E, FI-00810  
Helsinki, Finland

(email: kristina.eneroth@fmi.fi)

2. Norwegian Institute of Air Research, Polar Environmental Centre, N-9296 Tromsø,  
Norway

(email: kjh@nilu.no)

### INTRODUCTION

For a long time the Arctic was considered as a pristine region with little influence of airborne pollutants, but in the 1970s it was, however, recognized that the decrease in visibility during winter and early spring (Arctic Haze) could be due to long-range transports of pollutants into the Arctic (cf. *Rahn et al.*, 1977). Subsequently numerous studies have analyzed the relationship between the concentration of atmospheric constituents at Arctic monitoring stations and the synoptic-scale circulation. However, the majority of these investigations have been performed by single groups and been related to particular measurement programs. Such studies should be complemented with investigations where generalizations are made and the individual tracer concentrations are tested for mutual consistency. In this work we demonstrate the potential of trajectory climatologies to allow such generalizations. We examine how seasonal variations of air mass transport cause changes in the mixing ratio of different atmospheric species observed at the Mt. Zeppelin monitoring station, Ny-Ålesund (78°58' N, 11°53' E) using a trajectory climatology previously established in a study by *Eneroth et al.* (2003). The investigation comprises the years 1992-2001, with emphasis on episodes of ozone depletion in the lower troposphere in spring, on particle formation during summer, and on long-range transports of pollutants during winter.

### METHODS

#### *Monitoring at the Mt. Zeppelin station*

Long-term measurements of trace gases and aerosols in the European Arctic atmosphere have been performed at the Mt. Zeppelin station since 1989. The station is located on a mountain ridge (474 m asl), having steep slopes to the north and south and higher mountain peaks to the west and east. In the present study we focus on measurements of ozone (O<sub>3</sub>), volatile organic compounds (VOCs), gaseous elementary mercury (GEM), particle number concentration (CN), and the scattering coefficient ( $\sigma_{sp}$ ).

#### *Trajectory climatology*

We use 5-day back-trajectories calculated with the three-dimensional model of McGrath (1989) using wind fields from the European Centre for Medium-Range Weather Forecasts (ECMWF) operational model. Trajectories arriving at Ny-Ålesund at 850 hPa are calculated twice daily (00 and 12 UTC) during the 10-year period 1992-2001. To

classify the trajectories cluster analysis is employed. This multivariate statistical method separates the trajectories into groups or clusters by maximizing the similarity of their shapes and lengths. The transport climatology for Ny-Ålesund during 1992-2001 is shown in Figure 1. The clusters are depicted as mean trajectories, describing potential source areas within a 5-day transport time to Ny-Ålesund. Each cluster is assigned an identification number (1-8). Clusters 1-4 represent transport across the Arctic Basin, whereas clusters 5-8 comprise trajectories originating from the Eurasian continent and the Atlantic. The caption of Figure 1 shows the mean frequency of occurrence of the transport clusters. The distribution of trajectories between these flows is similar for all years during the ten-year period. However, there are seasonal differences in when different clusters are most prevalent.

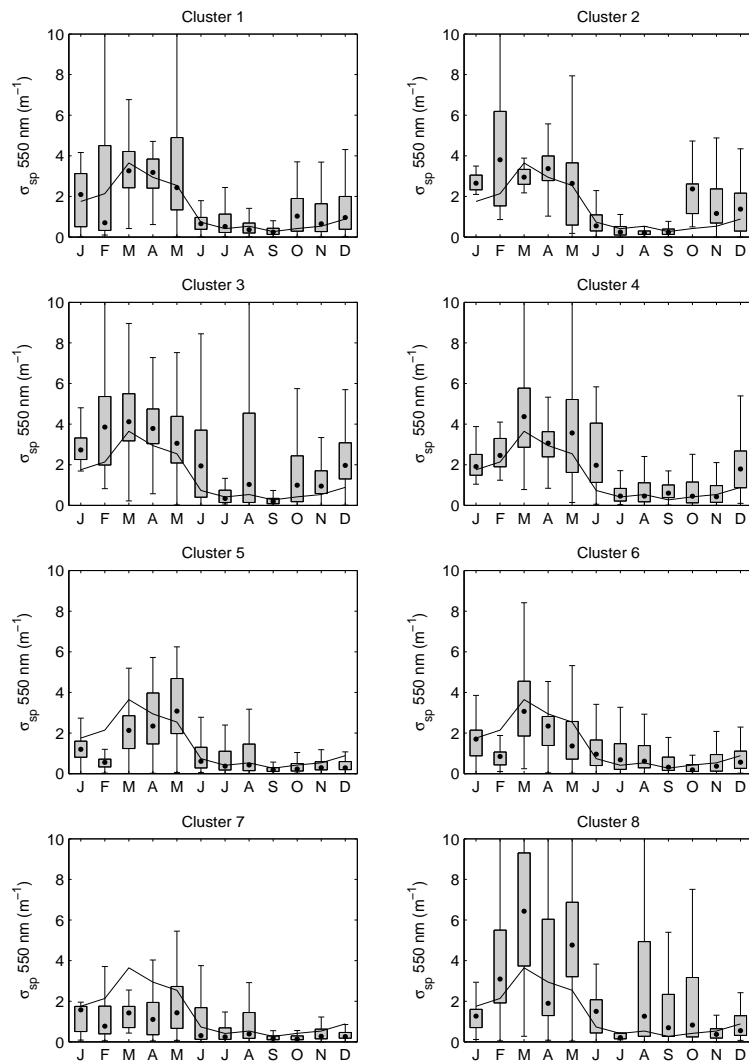

**Figure 1.** Transport paths to Ny-Ålesund illustrated by cluster mean trajectories, denoted 1-8. Percent occurrence of trajectories within each cluster is as follows: cluster 1, 17%; cluster 2, 9%; cluster 3, 15%; cluster 4, 11%; cluster 5, 9%; cluster 6, 17%; cluster 7, 8%; and cluster 8, 13%.

## RESULTS AND DISCUSSION

We apply the trajectory climatology to the trace gas and aerosol measurements at the Mt. Zeppelin station to examine how variations in air transport to Svalbard are reflected in the atmospheric records. The largest anthropogenic signal at Mt. Zeppelin is found during winter and early spring due to the lack of sunlight, the stable atmosphere, the low rate of scavenging, and the frequent poleward transport from polluted areas in Europe and Siberia. This is illustrated in Figure 2 as a peak in the aerosol scattering during winter and early spring. From the figure it can also be seen that the highest aerosol scattering is observed in connection with southeasterly transport from Europe (cluster 8), but also with northeasterly transport from Siberia (cluster 3). These transport patterns are also found to be associated with high concentrations of CN. This is in accordance with previous studies (cf. *Pacyna et al.*, 1985; *Heintzenberg*, 1989), distinguishing Europe and Siberia as source regions for Arctic Haze. On the other hand, air transport from marine mid-latitudes (clusters 5-7) is associated with lower-than-average aerosol scattering and CN concentrations, which may be due to wet scavenging and/or low emissions of particles over the oceans.





**Figure 2.** Box whisker diagrams of for the aerosol scattering coefficient at Ny-Ålesund ( $78^{\circ}58' \text{ N}$ ,  $11^{\circ}53' \text{ E}$ ) during 1997-2001 for different transport patterns. The box has a dot at the median value and lines at the lower quartile and upper quartile values. The whiskers are lines extending from each end of the box to show the extent of the rest of the data. The curve shows the median aerosol scattering coefficient for all data, regardless of transport pattern.

The springtime  $\text{O}_3$  depletion events are found to be most frequent in connection with air transport across the Arctic Basin, and in some cases also during transport from the Norwegian Sea. Analyzing the height of the trajectories within each cluster, we find that the  $\text{O}_3$ -loss is most pronounced in air masses which have been advected close to the surface. This result supports the idea that the  $\text{O}_3$  depletion reactions take place in the lowermost part of the atmosphere in the central Arctic Basin. The highest CN concentration is observed during summer in connection with air transport over the seas around Svalbard. Particularly high concentrations are observed during periods characterized by subsiding air. It can be hypothesized that trajectories descending from high altitudes are associated with clear sky conditions, suggesting that sunlight and photochemical reactions are the key parameters for new particle formation in the Arctic. Another hypothesis is that new particles are not primarily produced near the surface, but

rather that precursor gases and/or particles are transported downwards from layers above. Since the trajectories have been in contact neither with the ocean surface nor continental areas during the last five days, the latter mechanism implies that either the precursor gases or the particles themselves have a lifetime of at least several days.

## CONCLUSIONS

The atmospheric transport to Svalbard is dominated by the Atlantic storm tracks in winter, whereas transport pathways from and across the Arctic Basin are more common during spring and summer. A small year-to-year variability of the atmospheric transport pathways during the 10 years of study is seen, but possibly there is a greater variability and/or trend over longer time-scales. Such variations in transport are essential to monitor since the shift in air mass statistics at a monitoring station can otherwise easily be interpreted as a trend in sources and sinks. The application of a trajectory climatology to trace gases and aerosols with various source and sink functions, atmospheric lifetimes as well as chemistry proved to be successful. However, the vertical transport and mixing were found to be crucial processes determining the observed mixing ratio of traces gases and aerosols. This aspect should be further examined. As cloudiness and precipitation are important parameters when interpreting atmospheric measurements (especially of aerosol particles, it would also be desirable to combine the trajectory climatology with precipitation and cloud data in future studies.

## ACKNOWLEDGEMENTS

Torunn Berg and Sverre Solberg at the Norwegian Institute for Air Research are acknowledged for providing the GEM data, and the O<sub>3</sub> and VOC data, respectively. We also thank the Norwegian Polar Institute for a fruitful cooperation. Ray McGrath at the Irish Meteorological Service is acknowledged for permission to use the software needed to calculate the trajectories. The Stockholm University atmospheric monitoring at Mt. Zeppelin station, Ny-Ålesund is supported by the Swedish Environmental Protection Agency.

## REFERENCES

- Eneroeth, K., Kjellström, E. and Holmén, K., 2003. A trajectory climatology for Svalbard; investigating how atmospheric flow patterns influence observed tracer concentrations. *Physics and Chemistry of the Earth* 28: p. 1191-1203.*
- Heintzenberg, J., 1989. Arctic Haze: air pollution in polar regions. *Ambio* 18: p. 50-55.*
- Pacyna, J. M., Ottar, B., Tomza, U. and Maenhaut, W., 1985. Long-range transport of trace elements to Ny-Ålesund, Spitsbergen. *Atmos. Environ.* 19: p. 857-865.*
- Rahn, K. A., Borys, R. D. and Shaw, G., 1977. The Asian source of Arctic Haze bands. *Nature* 286: p. 713-715.*

## TRACE ELEMENT DEPOSITION MEASUREMENTS AT PALLAS GAW STATION

Ulla Makkonen

Finnish Meteorological Institute, Sahaajankatu 20 E, FIN-00880 Helsinki, Finland  
(email: Ulla.Makkonen@fmi.fi)

### INTRODUCTION

Pallas back-ground station which is situated in North of Finland has been part of Global Atmospheric Watch programme since 1994. Precipitation samples and aerosol samples for the determination of trace elements have been collected at Pallas Matorova station (68°00'00'') from the beginning of 1996.

### MATERIALS AND METHODS

Monthly precipitation samples were collected for analysing the trace elements using bulk collectors (*EMEP Manual for Sampling and Chemical Analysis*, 1996). Twelve different trace elements (Al, As, Cd, Co, Cr, Cu, Pb, Mn, Ni, Fe, Zn and V) were determined from the precipitation samples using an ICP-MS (Perkin Elmer SCIEX Elan 6000).

### RESULTS AND DISCUSSION

The annual variations (from 1996 until 2003) of cadmium, arsenic and vanadium deposition together with the amount of precipitation (mm) are presented in Figure 1 and the annual variations of cadmium, cobber and zinc in Figure 2.

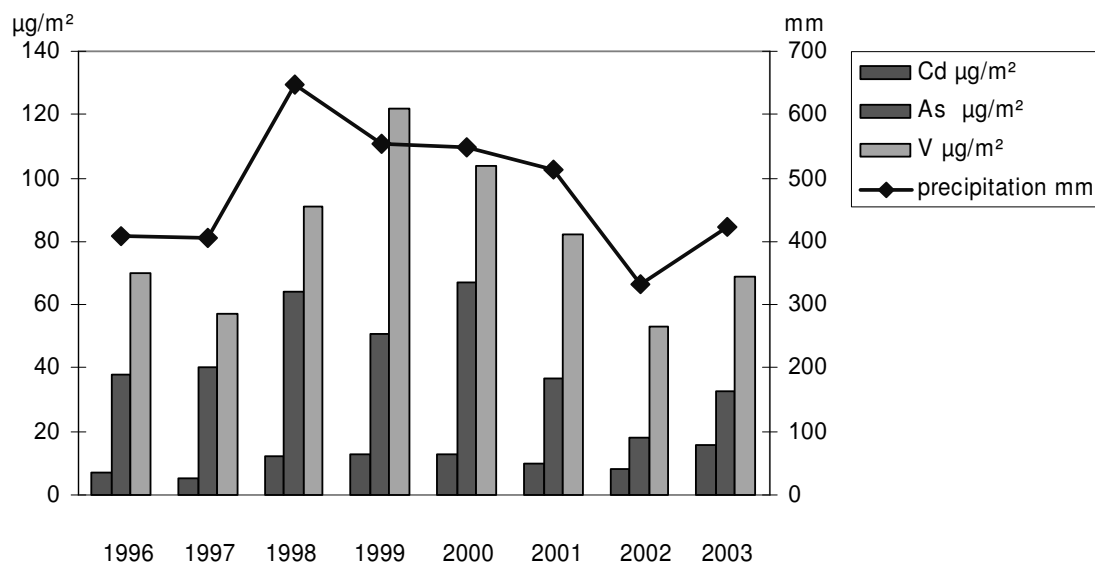

**Fig. 1.** Annual deposition of Cd, As and V at Pallas, Matorova 1996-2003.

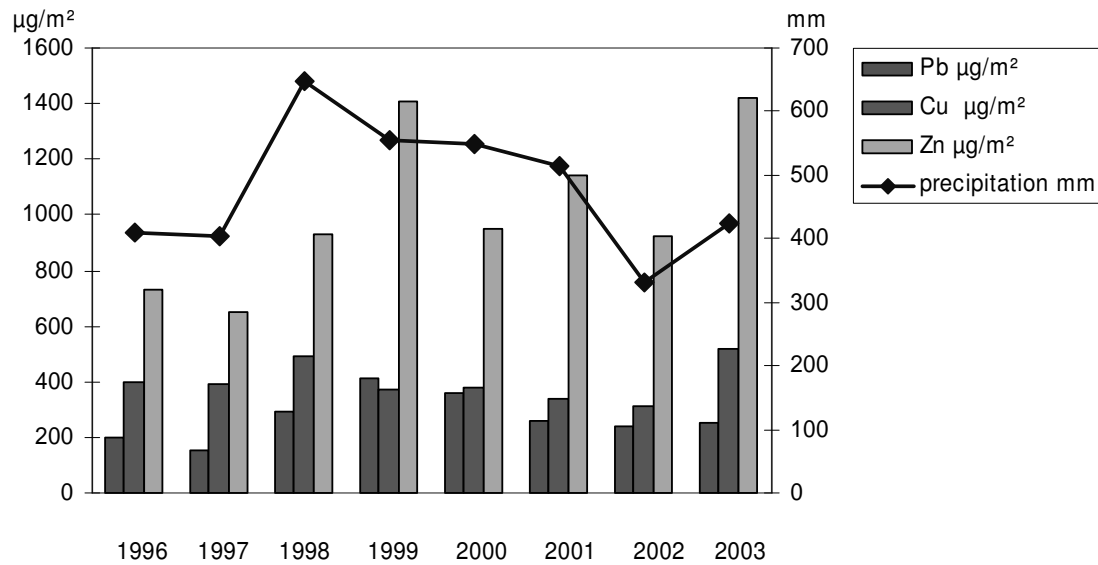

**Fig. 2.** Annual deposition of Pb, Cu and Zn at Pallas, Matorova 1996-2003.

The average annual depositions of cadmium, arsenic and vanadium were 10, 43 and 81  $\mu\text{g}/\text{m}^2$  respectively and for lead, cobber and zinc 270, 400 and 1019  $\mu\text{g}/\text{m}^2$ . The values do not show any clear trends. The lead and vanadium depositions at Pallas were one third or one fourth of the results measured at Virolahti and Utö in southern Finland and cadmium, arsenic and zinc depositions were about half of those measured in southern Finland.

#### REFERENCES

*EMEP Manual for sampling and chemical analysis 1/95*, NILU, 1996, Revisoin 1/2001.

*Air Quality Measurements 2000*, L. Leinonen (ed.), Finnish Meteorological Institute, 2001.



## RAPORTTEJA — RAPPORTER — REPORTS

- 1986:
1. Savolainen, Anna Liisa et al., 1986. Radioaktiivisten aineiden kulkeutuminen Tshernobylin ydinvoimalaonnettomuuden aikana. Väliaikainen raportti. 39 s.
  2. Savolainen, Anna Liisa et al., 1986. Dispersion of radioactive release following the Chernobyl nuclear power plant accident. Interim report. 44 p.
  3. Ahti, Kari, 1986. Rakennussääpalvelukokeilu 1985-1986. Väliraportti Helsingin ympäristön talvikokeilusta 18.11.-13.3.1986. 26 s.
  4. Korhonen, Ossi, 1986. Pintatuulen vertailumittauksia lentoasemilla. 38 s.
- 1987:
1. Karppinen, Ari et al., 1987. Description and application of a system for calculating radiation doses due to long range transport of radioactive releases. 50 p.
  2. Venäläinen, Ari, 1987. Ilmastohavaintoihin perustuva arvio jyrshinturpeen tuotantoedellytyksistä Suomessa. 35 s.
  3. Kukkonen, Jaakko ja Savolainen, Anna Liisa, 1987. Myrkyllisten kaasujen päästöt ja leviäminen onnettomuustilanteissa. 172 s.
  4. Nordlund, Göran ja Rantakrans, Erkki, 1987. Matemaattisfyysikaalisten ilmanlaadun arviointimallien luotettavuus. 29 s.
  5. Ahti, Kari, 1987. Rakennussäätutkimuksen loppuraportti. 45 s.
  6. Hakola, Hannele et al., 1987. Otsonin vaihteluista Suomessa yhden vuoden havaintoaineiston valossa. 64 s.
  7. Tammelin, Bengt ja Erkiö, Eero, 1987. Energialaskennan säätiedot – suomalainen testivuosi. 108 s.
- 1988:
1. Eerola, Kalle, 1988. Havaintojen merkityksestä numeerisessa säänennustuksessa. 36 s.
  2. Fredrikson, Liisa, 1988. Tunturisääprojekti 1986-1987. Loppuraportti. 31 s.

3. Salmi, Timo and Joffre, Sylvain, 1988. Airborne pollutant measurements over the Baltic Sea: meteorological interpretation. 55 p.
  4. Hongisto, Marke, Wallin, Markku ja Kaila, Juhani, 1988. Rikkipäästöjen vähentämistoimenpiteiden taloudellisesti tehokas valinta. 80 s.
  5. Elomaa, Esko et al., 1988. Ilmatieteen laitoksen automaattisten merisääasemien käyttövarmuuden parantaminen. 55 s.
  6. Venäläinen, Ari ja Nordlund, Anneli, 1988. Kasvukauden ilmastotiedotteen sisältö ja käyttö. 63 s.
  7. Nieminen, Rauno, 1988. Numeeristen paine- ja korkeuskenttäennusteiden objektiivinen verifiointisysteemi sekä sen antamia tuloksia vuosilta 1985 ja 1986. 35 s.
- 1989: 1. Ilvessalo, Pekko, 1989. Yksittäisestä piipusta ilmaan pääsevien epäpuhtauksien suurimpien tuntipitoisuuksien arviointimenetelmä. 21 s.
- 1992: 1. Mhita, M.S. and Venäläinen, Ari, 1991. The variability of rainfall in Tanzania. 32 p.
2. Anttila, Pia (toim.), 1992. Rikki- ja typpilaskeuman kehitys Suomessa 1980-1990. 28 s.
- 1993: 1. Hongisto, Marke ja Valtanen Kalevi, 1993. Rikin ja typen yhdisteiden kaukokulkeutumismallin kehittäminen HIRLAM-sääennustemallin yhteyteen. 49 s.
2. Karlsson, Vuokko, 1993. Kansalliset rikkidioksidin analyysivertailut 1979 - 1991. 27 s.
- 1994: 1. Komulainen, Marja-Leena, 1995. Myrsky Itämerellä 28.9.1994. Säätilan kehitys Pohjois-Itämerellä M/S Estonian onnettomuusyönä. 42 s.
2. Komulainen, Marja-Leena, 1995. The Baltic Sea Storm on 28.9.1994. An investigation into the weather situation which developed in the northern Baltic at the time of the accident to m/s Estonia. 42 p.
- 1995: 1. Aurela, Mika, 1995. Mikrometeorologiset vuomittausmenetelmät - sovelluksena otsonin mittaaminen suoralla menetelmällä. 88 s.

2. Valkonen, Esko, Mäkelä, Kari ja Rantakrans, Erkki, 1995. Liikenteen päästöjen leviäminen katukuilussa - AIG-mallin soveltuvuus maamme oloihin. 25 s.
  3. Virkkula, Aki, Lättilä, Heikki ja Koskinen, Timo, 1995. Otsonin maanpintapitoisuuden mittaaminen UV-säteilyn absorptiolla: DOAS-menetelmän vertailu suljettua näytteenottoalaa käyttävään menetelmään. 29 s.
  4. Bremer, Pia, Ilvessalo, Pekko, Pohjola, Veijo, Saari, Helena ja Valtanen, Kalevi, 1995. Ilmanlaatuennusteiden ja -indeksin kehittäminen Helsingin Käpylässä suoritettujen mittausten perusteella. 81 s.
- 1996:
1. Saari, Helena, Salmi, Timo ja Kartastenpää, Raimo, 1996. Taajamien ilmanlaatu suhteessa uusiin ohjearvoihin. 98 s.
- 1997:
1. Solantie, Reijo, 1997. Keväthallojen alueellisista piirteistä ja vähän talvipakkastenkin. 28 s.
- 1998:
1. Paatero, Jussi, Hatakka, Juha and Viisanen, Yrjö, 1998. Concurrent measurements of airborne radon-222, lead-210 and beryllium-7 at the Pallas-Sodankylä GAW station, Northern Finland. 26 p.
  2. Venäläinen, Ari ja Helminen, Jaakko, 1998. Maanteiden talvikunnossapidon sääindeksi. 47 s.
  3. Kallio, Esa, Koskinen, Hannu ja Mälkki, Anssi, 1998. VII Suomen avaruustutkijoiden COSPAR-kokous, Tiivistelmät. 40 s.
  4. Koskinen, H. and Pulkkinen, T., 1998. State of the art of space weather modelling and proposed ESA strategy. 66 p.
  5. Venäläinen, Ari ja Tuomenvirta Heikki, 1998. Arvio ilmaston lämpenemisen vaikutuksesta teiden talvikunnossapidon kustannuksiin. 19 s.
- 1999:
1. Mälkki, Anssi, 1999. Near earth electron environment modelling tool user/software requirements document. 43 p.
  2. Pulkkinen, Antti, 1999. Geomagneettisesti indusoituvat virrat Suomen maakaasuverkostossa. 46 s.
  3. Venäläinen, Ari, 1999. Talven lämpötilan ja maanteiden suolauksen välinen riippuvuus Suomessa. 16 s.



- 4 Koskinen, H., Eliasson, L., Holback, B., Andersson, L., Eriksson, A., Mälkki, A., Nordberg, O., Pulkkinen, T., Viljanen, A., Wahlund, J.-E., Wu, J.-G., 1999. Space weather and interactions with spacecraft : spee final report. 191 p.
- 2000: 1 Solantie, Reijo ja Drebs, Achim, 2000. Kauden 1961 - 1990 lämpöoloista kasvukautena alustan vaikutus huomioiden, 38 s.
- 2 Pulkkinen, Antti, Viljanen, Ari, Pirjola, Risto, and Bear working group, 2000. Large geomagnetically induced currents in the Finnish high-voltage power system. 99 p.
- 3 Solantie, R. ja Uusitalo, K., 2000. Patoturvallisuuden mitoitussadannat: Suomen suurimpien 1, 5 ja 14 vrk:n piste- ja aluesadantojen analysointi vuodet 1959 - 1998 kattavasta aineistosta. 77 s.
- 4 Tuomenvirta, Heikki, Uusitalo, Kimmo, Vehviläinen, Bertel, Carter, Timothy, 2000. Ilmastonmuutos, mitoitussadanta ja patoturvallisuus: arvio sadannan ja sen ääriarvojen sekä lämpötilan muutoksista Suomessa vuoteen 2100. 65 s.
- 5 Viljanen, Ari, Pirjola, Risto and Tuomi, Tapio, 2000. Abstracts of the URSI XXV national convention on radio science. 108 p.
- 6 Solantie, Reijo ja Drebs, Achim, 2000. Keskimääräinen vuoden ylin ja alin lämpötila Suomessa 1961 - 90. 31 s.
- 7 Korhonen, Kimmo, 2000. Geomagneettiset mallit ja IGRF-appletti. 85 s.
- 2001: 1 Koskinen, H., Tanskanen, E., Pirjola, R., Pulkkinen, A., Dyer, C., Rodgers, D., Cannon, P., Mandeville, J.-C. and Boscher, D., 2001. Space weather effects catalogue. 41 p.
- 2 Koskinen, H., Tanskanen, E., Pirjola, R., Pulkkinen, A., Dyer, C., Rodgers, D., Cannon, P., Mandeville, J.-C. and Boscher, D., 2001. Rationale for a european space weather programme. 53 p.
- 3 Paatero, J., Valkama, I., Makkonen, U., Laurén, M., Salminen, K., Raittila, J. and Viisanen, Y., 2001. Inorganic components of the ground-level air and meteorological parameters at Hyytiälä, Finland during the BIOFOR project 1998-1999. 48 p.

- 4 Solantie, Reijo, Drebs, Achim, 2001. Maps of daily and monthly minimum temperatures in Finland for June, July, and August 1961-1990, considering the effect of the underlying surface. 28 p.
  - 5 Sahlgren, Vesa, 2001. Tuulikentän alueellisesta vaihtelusta Längelmävesi-Roine -järvalueella. 33 s.
  - 6 Tammelin, Bengt, Heimo, Alain, Leroy, Michel, Rast, Jacques and Sääntti, Kristiina, 2001. Meteorological measurements under icing conditions : EUMETNET SWS II project. 52 p.
- 2002:
- 1 Solantie, Reijo, Drebs, Achim, Kaukoranta, Juho-Pekka, 2002. Lämpötiloja eri vuodenaikoina ja eri maastotyyeissä Alajärven Möksyssä. 57 s.
  2. Tammelin, Bengt, Forsius, John, Jylhä, Kirsti, Järvinen, Pekka, Koskela, Jaakko, Tuomenvirta, Heikki, Turunen, Merja A., Vehviläinen, Bertel, Venäläinen, Ari, 2002. Ilmastonmuutoksen vaikutuksia energiantuotantoon ja lämmitysenergian tarpeeseen. 121 s.
- 2003:
1. Vajda, Andrea and Venäläinen, Ari, 2003. Small-scale spatial variation of climate in northern Finland. 34 p.
  2. Solantie, Reijo, 2003. On definition of ecoclimatic zones in Finland. 44 p.
  3. Pulkkinen, T.I., 2003. Chapman conference on physics and modelling of the inner magnetosphere Helsinki, Finland, August 25 -29, 2003. Book of abstracts. 110 p.
  4. Pulkkinen, T. I., 2003. Chapman conference on physics and modelling of the inner magnetosphere Helsinki, Finland, August 25 -29, 2003. Conference program. 16 p.
  5. Merikallio, Sini, 2003. Available solar energy on the dusty Martian atmosphere and surface. 84 p.
  6. Solantie, Reijo, 2003. Regular diurnal temperature variation in the Southern and Middle boreal zones in Finland in relation to the production of sensible heat. 63 p.
- 2004:
1. Solantie, Reijo, Drebs, Achim and Kaukoranta, Juho-Pekka, 2004. Regular diurnal temperature variation in various landtypes in the Möksy experimental field in summer 2002, in relation to the production of sensible heat. 69 p.

2. Toivanen, Petri, Janhunen, Pekka and Koskinen, Hannu, 2004. Magnetospheric propulsion (eMPii). Final report issue 1.3. 78 p.
3. Tammelin, Bengt et al., 2004. Improvements of severe weather measurements and sensors – EUMETNET SWS II project. 101 p.
4. Nevanlinna, Heikki, 2004. Auringon aktiivisuus ja maapallon lämpötilan vaihtelut 1856-2003. 43 s.
5. Ganushkina, Natalia and Pulkkinen, Tuija, 2004. Substorms-7: Proceedings of the 7th International Conference on Substorms. 247 p.
6. Venäläinen, Ari, Sarkkula, Seppo, Wiljander, Mats, Heikkinen, Jyrki, Ervasto, Erkki, Poussu, Teemu ja Storås, Roger, 2004. Espoon kaupungin talvikunnossapidon sääindeksi. 17 s.
7. Paatero, Jussi and Holmén, Kim (Eds.), 2004. The First Ny-Ålesund – Pallas-Sodankylä Atmospheric Research Workshop, Pallas, Finland 1-3 March 2004 – Extended Abstracts. 61 p.